



Job _____
Item# _____

Platinum Series

Standard Features

- Holds fried foods as it drains oil into a pull-out collection drawer
- Stainless steel drain pan with removable perforated drain screen
- Stainless steel front, sides, rear and exterior bottom
- Stainless steel cabinet interior
- Free battery design assistance
- Warranty: two years on specified operational parts and two years on labor.



P16C-DC shown with optional Heat Lamp and 24" Flue Riser

STANDARD CONSTRUCTION SPECIFICATIONS

Exterior Finish: Front, sides, rear and exterior bottom constructed of stainless steel.

Drain Cabinet:Stainless steel drain pan with removable perforated drain screen. Stainless steel oil collection drawer. Stainless steel interior.



Models: P16C-DC

Dimensions -in (mm)

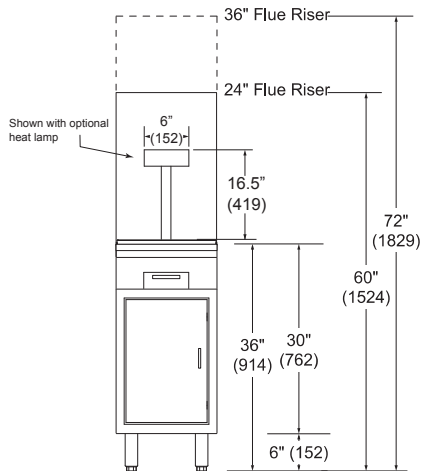

Model P16C-DC
(Drain Cabinet)

FRONT VIEW

Flue riser for "deep" depth-option extends rearward 6"
(Drain pan size is the same as for "standard" depth).

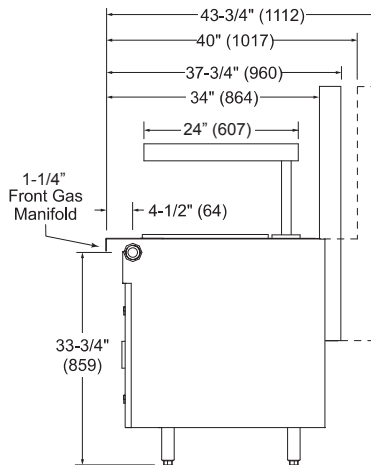

SIDE VIEW

SHIPPING CRATE DIMENSIONS & WEIGHT (Door-entry clearance when uncrated is 16.5" for Model P16C-DC)					
Model	Width	Height	Depth	Volume	Weight
P16C-DC	20.0 (508)	45.0 (1143)	42.5 (1080)	22.1 cu ft (0.63 cu m)	210 lbs (95 kg)

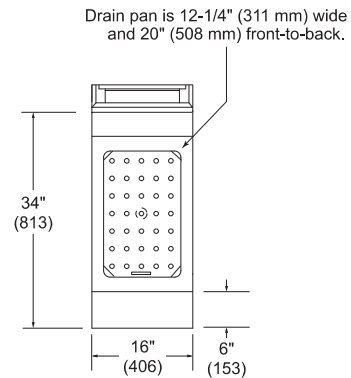

TOP VIEW

UTILITY INFORMATION

Gas:

- These units do not use gas, but have a 1-1/4" front gas manifold that couples to the adjacent sectional unit(s), and a 1" rear gas connection with a male NPT connector.

MISCELLANEOUS

- If casters are used with flex hose, a restraining device should be used to eliminate undue strain on the flex hose.
- Minimum clearance from noncombustible construction is zero. Minimum clearance from combustible construction is 0" on sides and 0" on rear.
- Check local codes for fire and sanitary regulations.

NOTICE:

Southbend has a policy of continuous product research and improvement. We reserve the right to change specifications and product design without notice. Such revisions do not entitle the buyer to corresponding changes, improvements, additions or replacements for previously purchased equipment.

OPTIONS AND ACCESSORIES

- Heat lamp over drain pan (120 volt cord and plug)
- Casters (in lieu of legs, front two casters lock)
- 24" Flue Riser
- 36" Flue Riser

**INTENDED FOR COMMERCIAL USE ONLY.
NOT FOR HOUSEHOLD USE.**



1100 Old Honeycutt Road, Fuquay-Varina, NC 27526
(919) 762-1000 www.southbendnc.com