



ELECTRIC COUNTER STEAMER AUTO FILL, MANUAL DRAIN



Model shown is an R18A-4M

SPECIFICATIONS:

Shall be a Southbend model **R18A-4M (4 pan)** counter convection steamer with electric steam generator, c-CSA-us and NSF certified. The steamer shall be constructed of #4 finish stainless steel type 304, with a cooking chamber of one piece all welded type 316 stainless steel with coved corners. The door shall have a removable inner liner of stainless steel with full perimeter gasket seal, an outer liner of one piece all welded stainless steel, and a positive lock and seal mechanism. The steamer shall be provided with removable stainless steel pan supports and 4" leveling legs.

The control housing shall be constructed of stainless steel with full access removable panel. The controls shall include an illuminated power switch, a pilot ready light, a pilot cook light, "60" minute electric timer which sounds an audible sound at the end of the cooking cycle. Steam flow to the cooking chamber shall be interrupted when the door is opened and shall be reactivated when door is closed. Standard features include a de-liming port located at the rear of the unit for easy access to allow cleaning of the generator tank, manual blow-down valve, solid state liquid level controls and split water connections for simple hook up to a water treatment system.

NOTE: DRAIN PAN PROVIDED BY OTHERS.

SEE REVERSE SIDE OF SPEC SHEET FOR WATER TREATMENT SYSTEM STATEMENTS

Model	Compartment Pan Capacity			
	PanDepth			
	1"	2-1/2"	4"	6"
R18A-4M	8	4	2	2

OPERATION SHALL BE BY:

Electrically heated, boiler free steam generation rated at:

- 10 kW for Model R18A-4M

The steam generator shall be equipped for operation on:

- 208 VAC, 3 Phase, 50/60 Hz *
- 240 VAC, 3 Phase, 50/60 Hz *
- 220 VAC, 3 Phase, 50/60 Hz *

***- UNIT SHALL BE FIELD CONVERTIBLE TO SINGLE PHASE AND ALSO CONFIGURABLE TO 2/3 RATING.**

6 kW for model R18A-4M

STANDARD FEATURES:

- Automatic water fill system, manual drain system
- 304 stainless steel exterior
- 316 stainless steel cooking chamber with coved corners
- Heavy gauge stainless steel door with full perimeter gasket
- Positive lock and seal mechanism with spring release door
- On/Off power switch
- Ready indicator light
- Cooking indicator light
- 60 minute electromechanical timer with end of cycle audible alarm
- Removable stainless steel pan supports
- Electromechanical controls.
- 4" adjustable legs
- Water supply in "Y" strainer

OPTIONS AND ACCESSORIES:

- 380 VAC, 3 phase, 50/60 Hz
- 415 VAC, 3 phase, 50/60 Hz
- 380/220 VAC, 3 Phase, 50/60 Hz 4 wire
- 415/240 VAC, 3 Phase, 50/60 Hz 4 wire
- Correctional package
- Constant steam feature
- 120 minute timer
- Drain hose kit
- 28" high single unit stand and double unit stacking stands available (Contact factory for details)



Models: R18A-4M

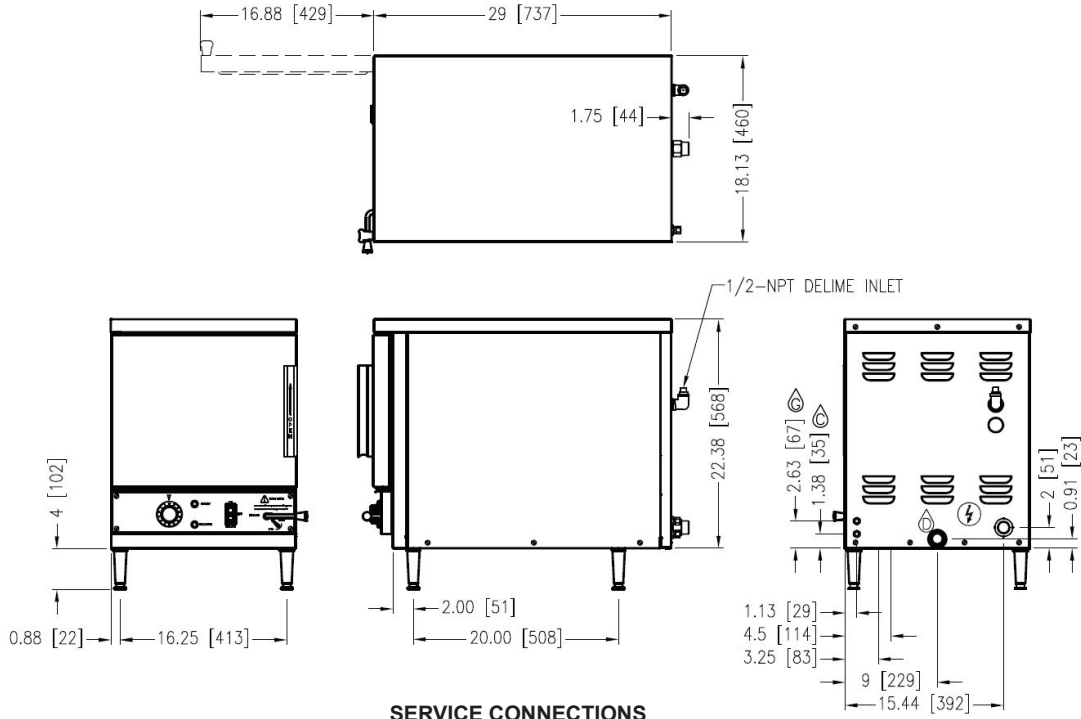

SERVICE CONNECTIONS

- ⚡ – ELECTRICAL CONNECTION: \varnothing 1 1/8" hole for electrical connection. Rating to be as specified on data plate.
- Ⓒ – COLD WATER: 3/8" (10 mm) O.D. tubing at 25-50 psi (170-345 kPa),
- Ⓖ – GENERATOR WATER 3/8" (10 mm) O.D. tubing at 25-50 psi (170-345 kPa)
- Ⓓ – DRAIN: 1" NPT

ELECTRICAL CHARACTERISTICS

MODEL	kW	AMPS/PHASE							
		208V		220V		240V		380V 8.4kW	415V
		1 PH	3 PH	1 PH	3 PH	1 PH	3 PH	3 PH	3 PH
R18A-4M	9	48.1	27.8	38.2	22.1	41.7	24.1	12.8	13.9
	6	28.9	N/A	27.3	N/A	25.0	N/A	N/A	N/A

PAN CAPACITIES

MODEL	PAN DEPTH	INCHES	1"	2.5"	4"	6"	SHIPPING WEIGHT	MINIMUM CLEARANCE	
		MM	25	64	102	152		SIDES	BACK
R18A-4M	Total Quantity of Pans		8	4	2	2	155 lbs. [70 kg]	0	0

WATER QUALITY STATEMENT

Water quality is the major factor affecting the performance of your appliance. If you are unsure of water quality, consult a local water treatment specialist and have the water analyzed. Your water supply must be within these general guidelines:

- Total dissolved solids.....Less than 60 PPM
- Total alkalinityLess than 20 PPM
- Silica.....Less than 13 PPM
- ChlorineLess than 1.5 PPM
- pH Factor7.0 - 8.5

Water which fails to meet these standards should be treated by installation of water conditioner.

FAILURE OR MALFUNCTION OF THIS APPLIANCE DUE TO POOR WATER QUALITY IS NOT COVERED UNDER WARRANTY.

For additional charge, SOUTHBEND auto-fill countertop steam units can be shipped with either a complete water treatment system part number 1190861 (for single steamer) or 1190862 (for stacked steamers).

Reference www.southbendnc.com for complete water treatment system warranty details and restrictions.

**INTENDED FOR COMMERCIAL USE ONLY.
NOT FOR HOUSEHOLD USE.**



1100 Old Honeycutt Road, Fuquay-Varina, NC 27526
(919) 762-1000 www.southbendnc.com