

**Standard Features**  
**Blast Chiller/ Shock Freezer**

TC40-BCF-PT (Forty pan, pass through)

Job  
 \_\_\_\_\_  
 Item#  
 \_\_\_\_\_

- Safely and rapidly chills or freezes hot food to meet HACCP guidelines for proper food holdings
- Easy to use touch screen controller - HACCP function
- USB data ports
- 100% AISI 304 Grade Stainless Steel construction, interior and exterior
- Heated probes
- UV sterilization
- Water condensing tray
- R404a refrigerant
- Auto defrost with hot gas
- Easy snap in magnetic door gasket
- Interior round corners for easy cleaning
- (2) years limited parts and labor and (5) years compressor warranty (reference <http://www.southbendnc.com/service.html> for limited warranty details)



Model shown TC40-BCF-PT

MODEL	OUTPUT DATA	
	OUTPUT CHILLING	OUTPUT FREEZING
TC40-BCF-PT	194°F/ 37.4°F(+90°C/+3°C) 836 lbs (379 kg) within 90 min	194°F/0°F(+90°C/-18°C) 728 lbs (330 kg) within 270 min

**Environment**

- (CFC & HCFC free) R404a refrigerant.
- High-tech environmentally friendly CFC-HCFC free, Cyclopentane foaming, for longer lasting insulation properties
- Lower energy consumption and less CO2 emissions
- Made of almost 99% recyclable materials
- ISO 14001 Certified
- Remote condensing unit 25 feet maximum
- Door frame width 30" to accept standard manufactures trolley

**STANDARD CONSTRUCTION SPECIFICATIONS**

- Push fit magnetic door seal
- Polyurethane insulation 2 23/64" (60mm) thick CFC/HCFC free
- Ready for 2 Trolley GN/1 or PA (40 Pan)
- Easy-Clean covered interior
- Standard Stainless Steel back
- Exterior ramps are not included



Models:  TC40-BCF-PT

Dimensions -in (mm)

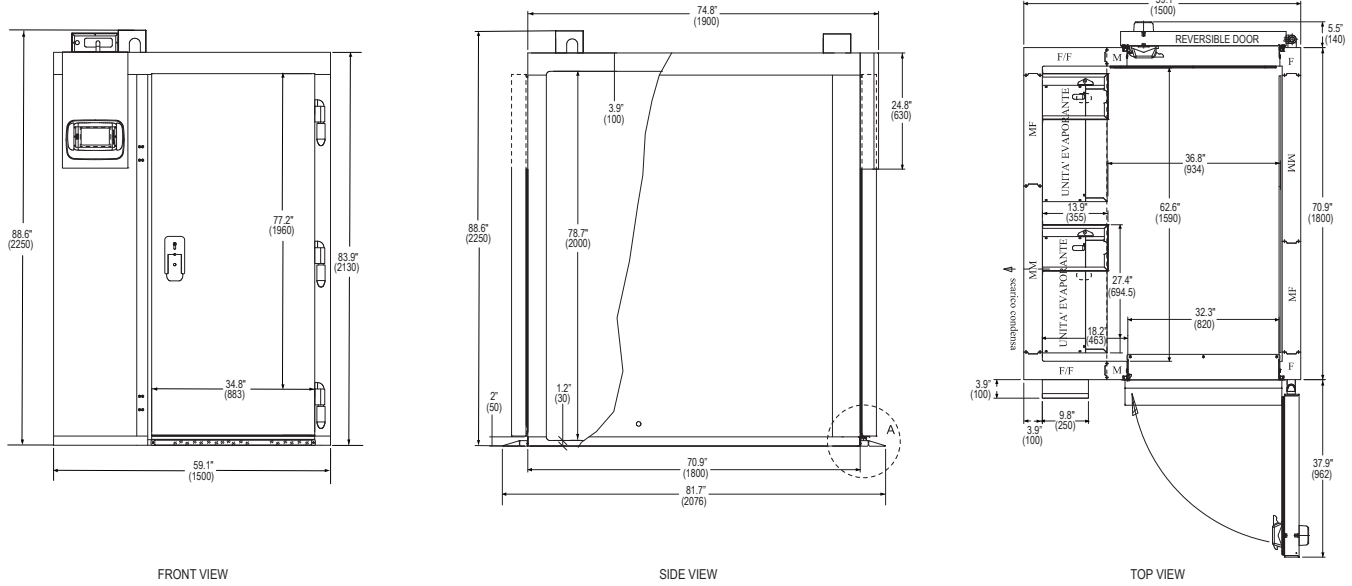

MODEL	UNIT DIMENSIONS				
	WIDTH	DEPTH	HEIGHT	VOLUME	WEIGHT
TC40-BCF-PT	59" (1500)	74.8" (1900)	88.6" (2250)	221 cu. ft. (6.26 cu. m.)	1450 lbs (656 kg)

Compressor Dimensions -in (mm)

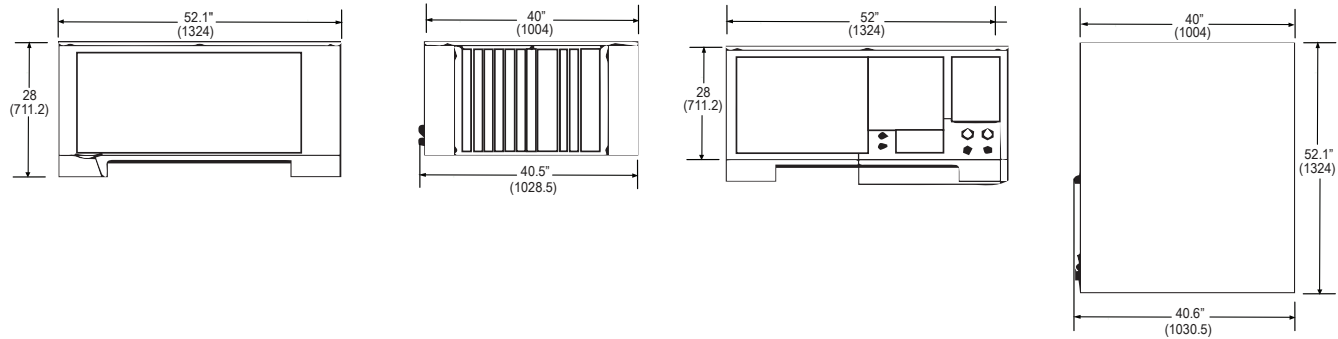

UTILITY INFORMATION

MODEL	VOLTAGE	Abs. POWER	BTU'S
TC40-BCF-PT	220V/60Hz/3P	FLA: Condensing Unit = 56A LRA: Condensing Unit = 212A FLA: Control Cabinet = 7A	54500 BTU/HR @ -4°F 41000 BTU/HR @ -40°F

MISCELLANEOUS

- Clearances from combustibles: Top-0", bottom-0", right side-0" and left-2"
- Check local codes for fire and sanitary regulations

**Notice:** Southbend reserves the right to change specifications and product design without notice. Such revisions do not entitle the buyer to corresponding changes, improvements, additions, or replacements for previously purchased equipment.

**INTENDED FOR COMMERCIAL USE ONLY.  
NOT FOR HOUSEHOLD USE.**



1100 Old Honeycutt Road, Fuquay-Varina, NC 27526  
(919) 762-1000 www.southbendnc.com