

DESIGNER LINE BASE MODEL

Model: DLRA60-SS-D

60" Base Model Worktop Refrigerator with Drawers and Solid Doors

Stainless steel exterior front, sides and interior.

Designed to maintain NSF-7 temperatures in 100°F ambient.



Options and Accessories

(upcharge and lead times may apply)

Door in lieu of drawers	Remote models
Drawer section above the condensing unit*	Digital thermometer
Automatic, electric condensate evaporator	Backsplash - BS models
Overshelves (single or double)	Front breathing
Additional epoxy-coated steel shelves	Casters
Condensing unit left or right	Door/drawer locks
Stainless steel back	

*Drawer section above condensing unit holds (1) 12 x 20 x 6 pan

Continental
Refrigerator

Toll-Free: 800-523-7138
Phone: 215-244-1400
Fax: 215-244-9579

539 Dunksferry Road
Bensalem, PA 19020
www.continentalrefrigerator.com

Project Name:

Model Specified:

Location:

Item No:

Quantity:

AIA #:

SIS #:

Standard Model Features

REFRIGERATION SYSTEM

Environmentally-safe R-134a refrigerant

Designed to maintain NSF-7 temperatures in 100°F ambient

Automatic, energy-saving, non-electric condensate evaporator

Non-corrosive, plasticized fin evaporator coil

Unique forced air design utilizes fans (approx. every 12") across the entire back of unit for even distribution of cold

CABINET ARCHITECTURE

2" non-CFC polyurethane foam insulation

Spring loaded, self closing doors (over condensing unit and smaller section)

Magnetic snap-in door/drawer gaskets

Stainless steel roll-out drawers

Heavy-duty, epoxy-coated steel shelf (smaller section)

Completely enclosed, vented and removable rear grill

Refrigerated door section above the condensing unit

Adjustable 6" stainless steel legs

MODEL FEATURES

Easily serviceable, slide-out condensing unit

Expansion valve for quick recovery

Built-in, off-cycle defrost timer

External dial thermometer

Field rehingeable doors

NOTE: DLRA60-D drawer models come standard with a door over the condensing unit, a solid door on the left section and two tier drawers in the center section. A drawer over the condensing unit is an option. The option of having the door/drawers located in the opposite sections **MUST** be indicated at the time of ordering.

APPROVAL:

Model Specifications

DIMENSIONAL DATA

Net Capacity (cu. ft.)	19 (538 cu l)
Width, Overall (in.)	60 (1524 mm)
Depth, Overall (in.) (incl. handles & bumpers)	36 1/16 (916 mm)
Height, Overall (in.) (incl. 5" legs)	36 (914 mm)
Shelf Area	5.6 (.5 sq m)
No. of Shelves	1
No. of Full Doors / Drawers	1 / 2
No. of Half Doors	1
Interior Depth (in.)	30 (762 mm)
Interior Height (in.) (smaller section)	26 (660 mm)
Interior Height (in.) (above condenser)	12 1/2 (318 mm)
Interior Width (in.) (smaller section)	17 (422 mm)
Interior Width (in.) (above condenser)	17 (422 mm)

REFRIGERANT DATA

Condensing Unit Size (H.P.)	1/2
Capacity (BTU/Hr)*	3100

ELECTRICAL DATA

Voltage (int'l)	115/60/1 (220/50/1)
Fans	3
Total Amps (int'l)	12.3 (8.4)
10 ft. Cord/Plug [attached] (int'l)	Yes (No)

SHIPPING DATA

Weight (lbs.)	415 (188 kg)
Height - Crated (in.)	43 3/4 (1111 mm)
Width - Crated (in.)	62 (1575 mm)
Depth - Crated (in.)	47 (1194 mm)

DRAWER PAN CONFIGURATIONS

Two Tier: (2) 12 x 20 x 6 pans per drawer

Three Tier: (1) 12 x 20 x 4 pan per drawer (top)
and (2) 12 x 20 x 4 pans per drawer (center & bottom)

* Rating @ +25°F evaporator, 90°F ambient

Figures in parentheses reflect metric equivalents rounded to the nearest whole unit.



Equipped with one NEMA-5-15P Plug
(varies by country)

Continental

Refrigerator

Toll-Free: 800-523-7138
Phone: 215-244-1400
Fax: 215-244-9579

539 Dunksferry Road
Bensalem, PA 19020
www.continentalrefrigerator.com

Due to our continued efforts in developing innovative products, specifications subject to change without notice.



MADE IN THE U.S.A.

© Copyright 2014. Continental Refrigerator.
A Division of National Refrigeration & Air Conditioning Products, Inc.

Model Plan Views

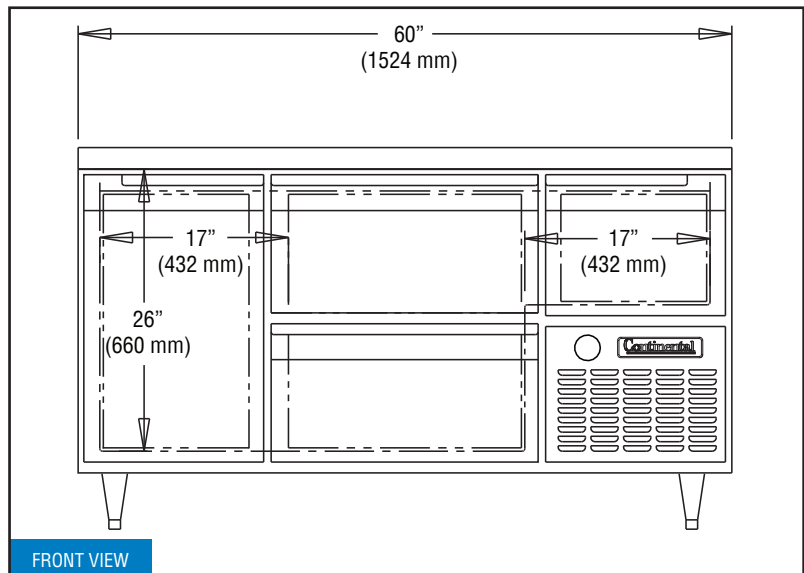

FRONT VIEW

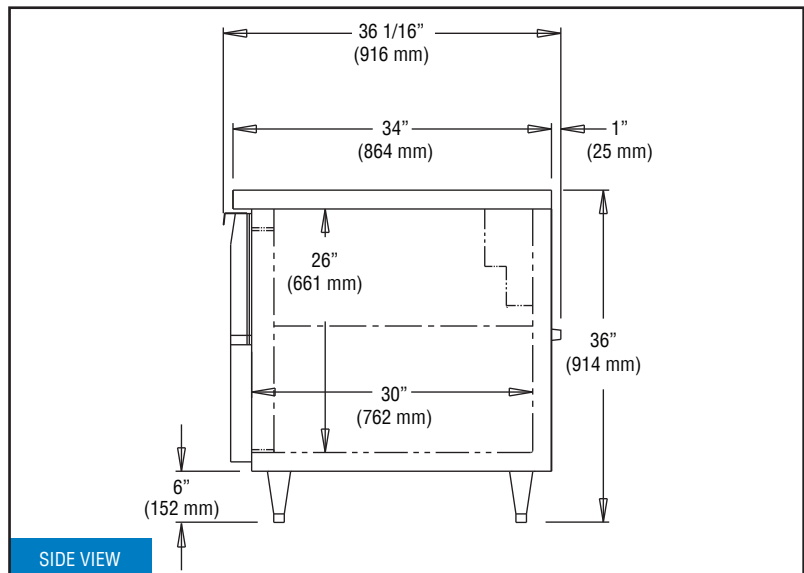

SIDE VIEW

REFRIGERATION SYSTEM

The self-contained refrigeration system is rear mounted, concealed behind a removable louvered cover. Full-length front air grille allows for even air circulation to condensing unit. A "performance rated", air-cooled, hermetically sealed, capillary type refrigeration system is installed in model. Plasticized finned coil and air circulating fans are contained within an easily accessible rear mounted housing. Our unique airflow design allows the cabinet to be enclosed on both sides or to be mounted flush against a wall. Our refrigeration system, fully charged with R-134a refrigerant, is designed to maintain 38°-41°F while operating with an unrestricted air supply in an ambient temperature of 100°F. All condensate water is directed to a non-electric condensate vaporizer located in the compressor compartment, no plumbing is required. A strict quality assurance team inspects all materials and components to certify that the model conforms to the most exacting standards. Model is performance tested for a minimum of 16 hours prior to crating.

DRAWER CONSTRUCTION

Drawer fronts and backs are constructed of heavy gauge, polished stainless steel with heavy-duty, safety grip, chrome plated handles. All drawer fronts are insulated with non-CFC polyurethane foam insulation. Full extension, lift-out type drawer frames are heavy gauge, welded stainless steel mounted on heavy-duty, easy glide, self closing drawer slides. Self adjusting, full perimeter, magnetic snap-in gaskets guarantee a positive seal.

DOOR CONSTRUCTION

Door shells are constructed of heavy-gauge stainless steel and are internally braced and urethane foam-insulated for rigidity. Door corners are of welded construction and polished. Replaceable snap-in door gaskets are self adjusting, heavy-duty, magnetic type. Door handles and hinges are chrome-plated and non-corrosive. Hinges are spring loaded, heavy duty and self-closing.

INSULATION

All cabinet walls, top and bottom have high density, foamed-in-place, non-CFC polyurethane insulation.

CABINET CONSTRUCTION

All materials are of top quality and are assembled under rigid supervision conforming to strict quality assurance requirements. Case is all welded metal construction and is internally supported and braced for rigid unit construction. Exterior, interior and worktop are heavy-gauge polished stainless steel for durability. Cabinet design eliminates overlapping panels with raw edges. Interior corners are rounded with a 1/4" radius for cleaning ease. All cabinet joints and seams are vapor-tight sealed. An easily removable anti-sweat drawer heater, concealed by a non-metallic, non-conductive, high impact thermal breaker strip, eliminates condensation build-up on case front.