

# WORKTOP REFRIGERATOR

**Model: SW32-D**

## 32" Worktop Refrigerator with Drawers

Stainless steel front and top, aluminum end panels, case back and interior.

**Designed to maintain NSF-7 temperatures in 100°F ambient.**



### Options and Accessories

(upcharge and lead times may apply)

Stainless steel exterior and interior	Expansion valve system
Stainless back in lieu of aluminum	Adjustable legs
Overshelves (single or double)	Remote models
Automatic electric condensate evaporator	Drawers locks
Door in lieu of drawers	Digital thermometer
Backsplash - BS models	Special electrical requirements (consult factory)
Glass door - GD models	

Consult factory for other model configurations, options and accessories.

**Continental**  
Refrigerator

Toll-Free: 800-523-7138  
Phone: 215-244-1400  
Fax: 215-244-9579

539 Dunksferry Road  
Bensalem, PA 19020  
[www.continentalrefrigerator.com](http://www.continentalrefrigerator.com)

Project Name:

Model Specified:

Location:

Item No:

Quantity:

AIA #:

SIS #:

### Standard Model Features

#### REFRIGERATION SYSTEM

Performance-rated refrigeration system

Environmentally-safe R-134a refrigerant

Automatic, energy-saving, non-electric condensate evaporator

Non-corrosive, plasticized fin evaporator coil

Easily serviceable back mounted compressor

#### CABINET ARCHITECTURE

2" non-CFC polyurethane foam insulation

Stainless steel roll-out drawers

Magnetic snap-in drawer gaskets

Completely enclosed, vented and removable case back

5" casters

#### MODEL FEATURES

Interior hanging thermometer

APPROVAL:

## Model Specifications

### DIMENSIONAL DATA

Net Capacity (cu. ft.)	9.0 (253 cu l)
Width, Overall (in.)	32 (813 mm)
Depth, Overall (in.) (incl. handles & bumpers)	31 7/16 (799 mm)
Depth, Body Only (less drawers) (in.)	27 1/2 (699 mm)
Height, Overall (in.) (incl. 5" casters)	35 1/4 (895 mm)
No. of Drawers (two tier)	2
No. of Drawers (three tier)	3

### REFRIGERANT DATA

Condensing Unit Size (H.P.)	1/5
Capacity (BTU/Hr)*	1620

### ELECTRICAL DATA

Voltage (int'l)	115/60/1 (220/50/1)
Fans	2
Total Amps (int'l)	6.3 (3.7)
10 ft. Cord/Plug [attached] (int'l)	Yes (No)

### SHIPPING DATA

Weight (lbs.)	221 (100 kg)
Height - Crated (in.)	43 1/4 (1099 mm)
Width - Crated (in.)	39 (991 mm)
Depth - Crated (in.)	37 1/4 (946 mm)

### DRAWER PAN CONFIGURATIONS

**Two Tier:** (1) 12 x 20 x 6 pan per drawer  
or (1) 1/2 size x 6 & (2) 1/3 x 6 pans per drawer

**Three Tier:** (1) 12 x 20 x 4 pan per drawer  
or (1) 1/2 size x 4 & (2) 1/3 x 4 pans per drawer

\* Rating @ +25°F evaporator, 90°F ambient

Figures in parentheses reflect metric equivalents rounded to the nearest whole unit.



Equipped with one NEMA-5-15P Plug  
(varies by country)

## Model Plan Views

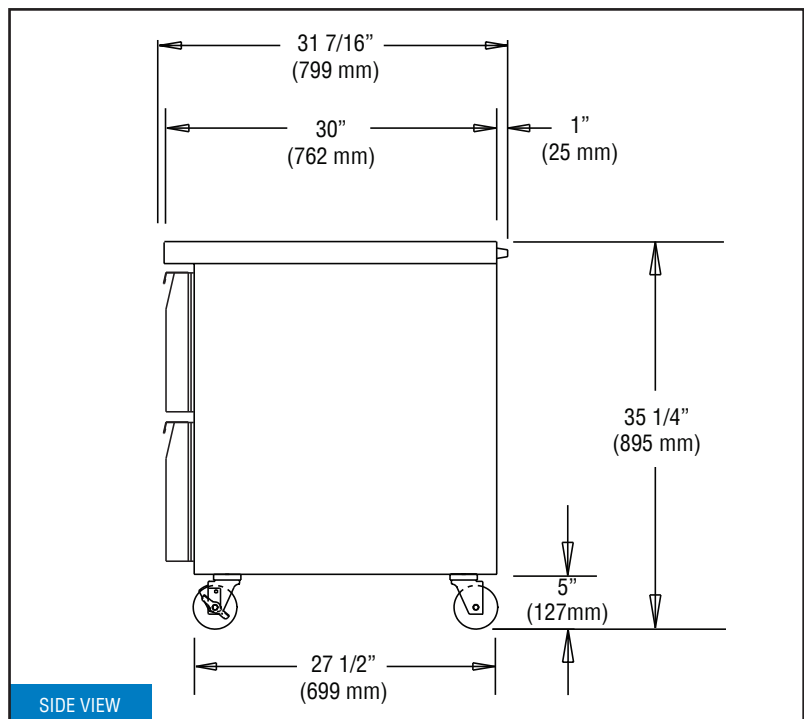
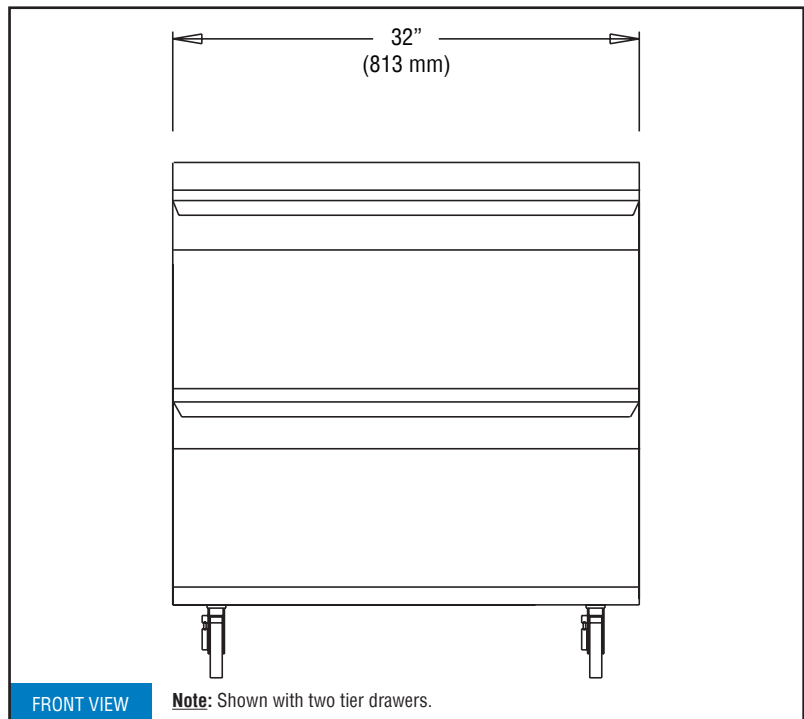

**Continental**  
Refrigerator

Toll-Free: 800-523-7138  
Phone: 215-244-1400  
Fax: 215-244-9579

539 Dunkserry Road  
Bensalem, PA 19020  
[www.continentalrefrigerator.com](http://www.continentalrefrigerator.com)

Due to our continued efforts in developing innovative products, specifications subject to change without notice.



MADE IN THE U.S.A.

© Copyright 2013. Continental Refrigerator.  
A Division of National Refrigeration & Air Conditioning Products, Inc.