

NOTE:

1. ALL VISIBLE WELDS TO BE GROUND SMOOTH AND POLISHED TO A MATCHING FINISH.
2. ALL NON-VISIBLE WELDS TO BE GROUND SMOOTH AND PAINTED WITH F.I. APPROVED PAINT
3. ALL EDGES TO BE SMOOTH & FREE FROM BURRS
4. ALL FABRICATION TECHNIQUES AND COMPONENTS TO BE APPROVED BY F.I. PRIOR TO FABRICATION
5. ALL TUBS TO BE DIE-STAMPED MIN. 1/4" TO INSURE PROPER DRAINAGE, ALL DRAIN HOLES TO BE RECESSED A MINIMUM OF 1/8" [3.18]

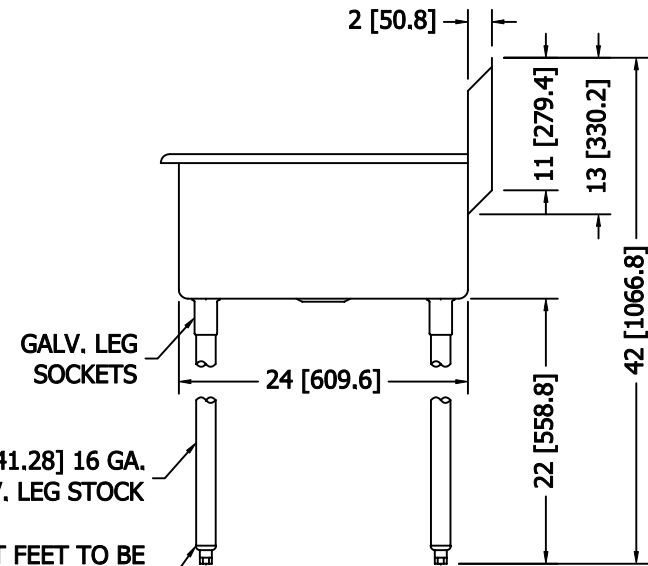
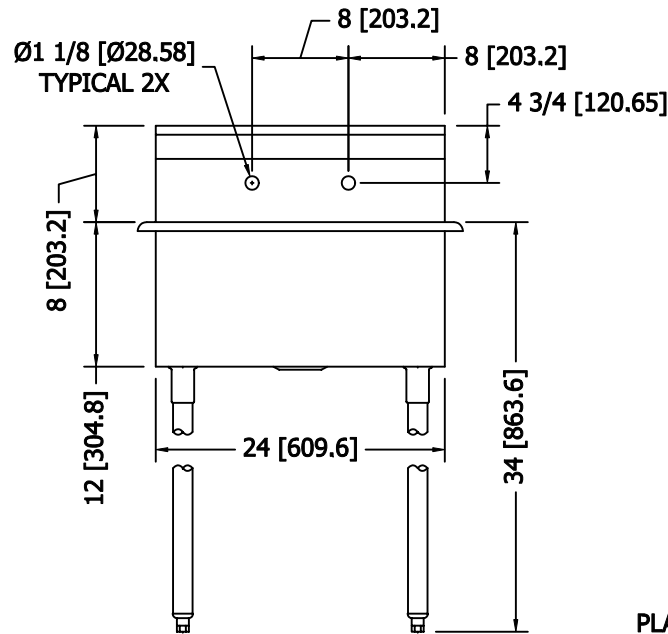

$\text{Ø}1\ 5/8$ [Ø41.28] 16 GA. [1.5] GALV. LEG STOCK
 PLASTIC BULLET FEET TO BE INSERT STYLE W/ MIN. OF 1" [25.4] OF ADJUSTABILITY