



Project Name: \_\_\_\_\_ AIA#: \_\_\_\_\_ Model #: \_\_\_\_\_

Location: \_\_\_\_\_ SIS#: \_\_\_\_\_ Item #: \_\_\_\_\_ Quantity: \_\_\_\_\_



# 20 Quart Bench Mixer

*Built into each mixer is the quality of workmanship and design synonymous with Globe.*

### Model

- SP20 - 20 Quart Planetary Mixer



GLOBE FOOD EQUIPMENT COMPANY

20 Quart Bench Mixer

### Standard Features

- Powerful 1/2 HP custom built motor
- Three fixed speeds
- Gear-driven, high torque transmission
- Heat-treated hardened steel alloy gears and shafts
- Permanently lubricated transmission
- Thermal overload protection
- Front-mounted digital controls with 60 minute timer and last batch recall
- Rigid cast iron body
- NSF approved enamel gray paint
- Industry standard #12 attachment hub
- Safety interlocked bowl guard and bowl lift

- Non-slip rubber feet
- 6 foot cord and ground plug

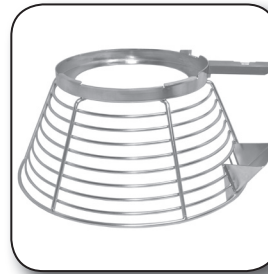

- High-quality stainless steel removable bowl guard with built-in ingredient chute
- Interlocking guard is easy to attach and remove for cleaning
- Dish machine safe

### Standard Accessories:

- 20 quart stainless steel bowl
- Flat beater (aluminum)
- Stainless steel wire whip
- Spiral dough hook (aluminum)

### Optional:

- Slicer/shredder/grater for #12 hub
- Meat grinder for #12 hub
- Flat beater (stainless steel)
- Spiral dough hook (stainless steel)
- 10 Qt adapter kit  12 Qt adapter kit
- Mixer table with undershelf
- Extended Warranty (More options on back)

### Warranty

- Two-year parts and one-year labor

SP20



GLOBE FOOD EQUIPMENT COMPANY  
2153 Dryden Rd., Dayton, OH 45439  
Phone: 937-299-5493 Fax: 937-299-4147  
800-347-5423

[www.globeslicers.com](http://www.globeslicers.com)

Approved By: \_\_\_\_\_

Date: \_\_\_\_\_



# 20 Quart Bench Mixer

# SP20

## SP20

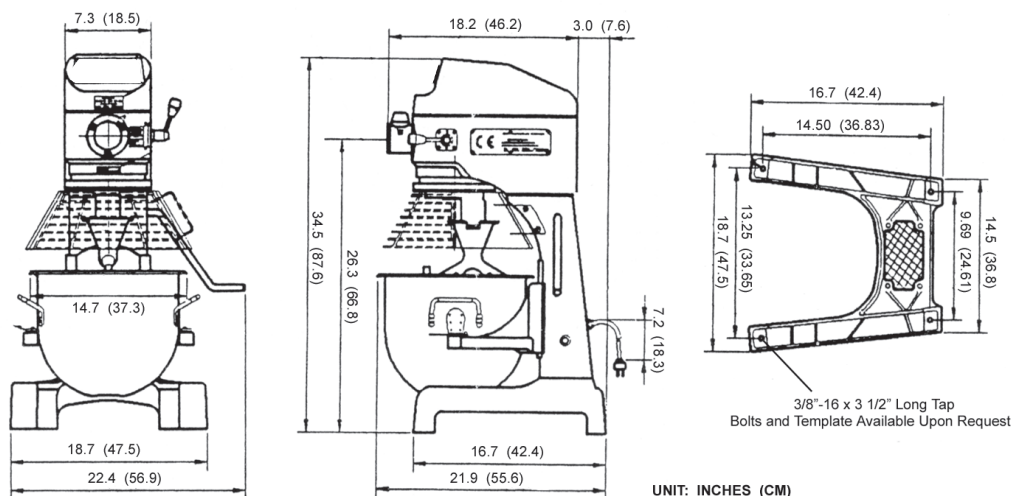

UNIT: INCHES (CM)

Drawings available through KCL. [www.kclcad.com](http://www.kclcad.com)

Model	Elevation	Right	Plan	Back	BIM 3D	Revit
SP20						

## SPECIFICATIONS

Model	Motor	Volts	Amps	Transmission Type	Capacity	Controls	Agitator Speeds (RPMs)			Attachment Speeds (RPMs)		
							1st	2nd	3rd	1st	2nd	3rd
SP20	1/2 HP	115/60/1	6	Gear	20 qt / 19 L	Front-mounted digital controls & timer	104	194	353	59	110	201

**Cord & Plug:** Attached 6 foot flexible 3-wire cord with molded plug fits a grounded receptacle. NEMA 5-15P (⚠)

### STANDARD ACCESSORIES:

- 20 Quart #304 series stainless steel bowl
- Aluminum spiral dough hook and flat beater
- Stainless steel wire whip and bowl guard with built-in ingredient chute

- **XXAWHIP-20** S/S Aileron (wing) whip
- **XXSCR-20** scraper with mounting kit
- **XXACC-10-20** Adapter kit - 10 qt bowl, hook, beater and whip
- **XXACC-12-20** Adapter kit - 12 qt bowl, hook, beater and whip
- **XXPASTRY-20** Alum. pastry knife
- **XTable** S/S countertop mixer table with under shelf (30" W x 24" D x 24" H)

- **CP16-12** 5/8" (16 mm)
- **CP18-12** 11/16" (18 mm)
- **CP00-12** Stuffing Plate
- **XST12** 1/2" stuffing tube (sheep)
- **XST34** 3/4" stuffing tube (hog)
- **XMCA-SS** Meat Grinder Assembly (Polished stainless steel cylinder, worm gear, ring, and s/s pan. Includes knife, 3/16" plate, and pusher.)
- **XXCK** Chopper knife for the XMCA-SS
- **XASP** Adjustable slicing plate (for vegetables only)
- **XVSGH** 9" Slicer/Shredder/Grater Housing Only (no plates included-must select from plates listed below)
- **XPH** Plate holder -\*only 1 required

### Shredding Plates:

- **XSP332\*** 3/32" (2.3 mm)
- **XSP316\*** 3/16" (4.7 mm)
- **XSP14\*** 1/4" (6.3 mm)
- **XSP516\*** 5/16" (7.9 mm)
- **XSP12\*** 1/2" (12.7 mm)
- **XGP\*** Grating plate

### OPTIONAL ATTACHMENTS & ACCESSORIES:

- **XXBOWL-20** Stainless steel bowl
- **XXBEAT-20** Alum. flat beater
- **XXBEAT-20SS** S/S flat beater
- **XXHOOK-20** Alum. dough hook
- **XXHOOK-20SS** S/S dough hook
- **XXJHOOK-20** Alum. J dough hook
- **XXWHIP-20** S/S wire whip
- **XXHDWHIP20-4** Heavy-duty 4 mm S/S wire whip

- Chopper Plate Sizes Available:
  - **CP02-12** 1/16" (2 mm)
  - **CP04-12** 5/32" (4 mm)
  - **CP05-12** 3/16" (5 mm)
  - **CP06-12** 1/4" (6 mm)
  - **CP08-12** 5/16" (8 mm)
  - **CP10-12** 3/8" (10 mm)
  - **CP12-12** 1/2" (12 mm)
  - **CP14-12** 9/16" (14 mm)

### FACTORY INSTALLED OPTION:

- **XXCORR-20** Correctional package includes tamper resistant external fasteners.

### EXTENDED WARRANTY

- **SP-XD1020** Extended warranty for the SP20 mixer. Coverage extends factory warranty to 2-years. Only available at time of purchase.

## DIMENSIONS & SHIPPING INFORMATION

Freight Class **85**

Cartons are reinforced for shipping. The weight and dimensions of this reinforced carton are included below and may vary from shipment to shipment. **This product ships on a pallet.**

Model	Foot Print	Overall Dimensions	Net Weight	Shipping Dimensions	Shipping Weight
SP20	16.7" D x 18.7" W (42 cm x 46 cm)	22" L x 22.4" W x 34.5" H (56 cm x 57 cm x 87.6 cm)	199 lbs. (80 kg)	40" L x 32" W x 48" H (102 cm x 81 cm x 122 cm)	270 lbs. (122 kg)



# GLOBE FOOD EQUIPMENT COMPANY

[www.globeslicers.com](http://www.globeslicers.com)

2153 Dryden Rd.  
Dayton, OH 45439  
Phone: 937-299-5493  
Phone: 800-347-5423  
Fax: 937-299-4147