

HCD-500/1000B

ICE BAGGING SYSTEM

Item # _____

Project: _____

Qty: _____

*AutoCad available on KCL

HCD-500/1000B

12/08

Item # 13237

DIMENSIONS

W x D x H

HCD-500B
30 x 36 x 71

HCD-1000B
48 x 36 x 71



HCD-500B

Ice Bagging System
Shown
with a KM-901MRH

HCD-1000B

Ice Bagging System

HCD-500B

- Ice storage capacity of 647 lbs. - ideal for limited space
- Safety overload lighted reset button

HCD-1000B

- Ice storage capacity of 1078 lbs.
- Equipped with Dual Agitators for easier ice management
- Built-in recovery safety torque overload

HCD- 500/1000B

- Unit has an ice drop rate of 120 lbs. per minute
- All stainless steel exterior finish
- Superior seamless poly liner unlike competitor units
- Stainless steel auger and agitator
- Front ice shovel door
- Stainless steel adjustable bag shelf
- 48" heavy duty ice paddle shipped with every dispenser
- Safety interlock door switch prevents operation when door is open
- 24V foot activated pedal
- 115v/60Hz/1 phase power supply



Warranty

Valid in United States, Canada, Puerto Rico, & U.S.Territories. Contact factory for warranty in other countries.

Contact the factory for details.



Hoshizaki

HCD-500/1000B ICE BAGGING SYSTEM

DIMENSIONS

W x D x H

HCD-500B

30 x 36 x 71

HCD-1000B

43 x 36 x 71

• Ice bagging system

SPECIFICATIONS

Model Number	Amperage	Min. Circuit Ampacity	Shipping Weight
HCD-500B	8.4	10.8	510 lbs.
HCD-1000B	8.4	10.8	590 lbs.

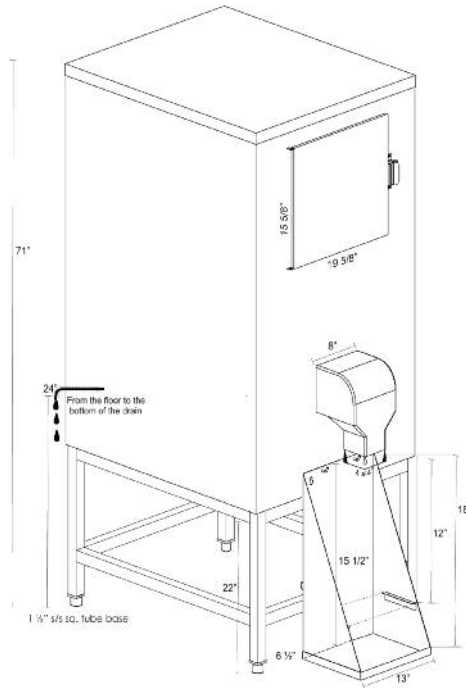

HCD-500B

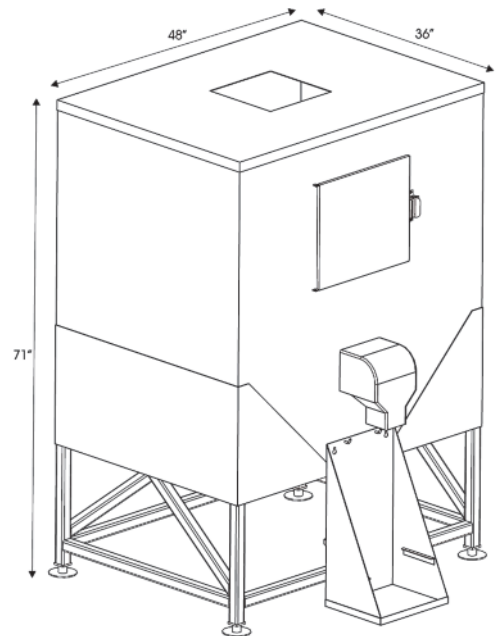

HCD-1000B

ELECTRICAL & PLUMBING / HCD-500/1000B

• 115V/60/1



© HOSHIZAKI AMERICA, INC.

618 Hwy. 74 S., Peachtree City, GA 30269

TEL 1-800-438-6087

FAX 1-800-345-1325

www.hoshizaki.com

Printed in U.S.A.

