

HW-2-1/2G
Enclosed Half Height
Bread Cabinet

Project _____

Item _____

Quantity _____

NU-VU® HW-2-1/2G Enclosed Half Height Bread Cabinet



SIZE:

HW-2-1/2G - 39-1/2" High, 22-1/8" Wide, 29-3/8" Deep
 1003 mm High, 562 mm Wide, 746 mm Deep

NU-VU's **HW-2-1/2G** enclosed bread cabinet features a lexan door for full view of product. The door features full gasket, which allows you to hold your baked product for extended periods of time without drying. The double top vent allows for hot product to cool without moisture accumulation.

The HW-2-1/2G holds either 18" x 26" full size or 13" x 18" half size sheet pans and comes fully assembled.

CONSTRUCTION:

- Aluminum construction

STANDARD FEATURES:

- Casters
- Adjustable double top vent
- Removable interior side walls
- Full view polycarbonate door
- Silicone rubber door gasket
- Lift off door

LABORATORY CERTIFICATION AND APPROVAL



NU-VU® Food Service Systems

www.nu-vu.com
 5600 13th Street
 Menominee, MI 49858

1-800-338-9886 Toll Free
 1-906-863-4401 Phone
 1-906-863-5889 Fax

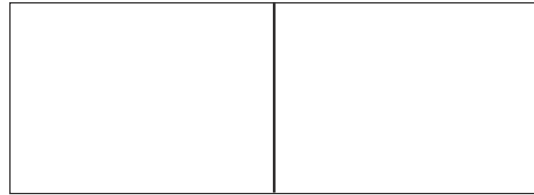

Approval / Stamp

HW-2-1/2G Enclosed Half Height Bread Cabinet

NU-VU® HW-2-1/2G Enclosed Half Height Bread Cabinet

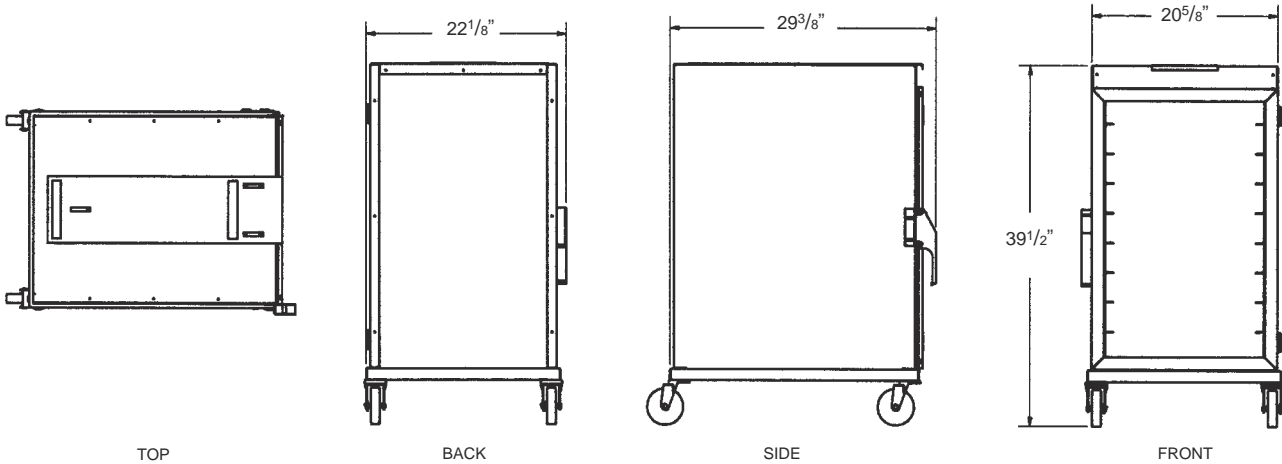

SPECIFICATIONS:

LISTINGS:

The HW-2-1/2G has NSF listings.



CAPACITY:

	18"x26" Sheet Pans	13"x18" Sheet Pans	Spacing
Cabinet	9	18	3-1/4"

DIMENSIONS:

	Height	Width	Depth
Exterior	39-1/2"	22-1/8"	29-3/8"
Interior	30-5/16"	18-1/2"	26-5/8"

DOOR SWING: Cabinet - 22" (559 mm)

PACKING SIZE:

40" High, 26" Wide, 34" Deep
(1016 mm High, 660 mm Wide, 364 mm Deep)

SHIPPING WEIGHT:

75 Pounds, FOB Menominee, MI 49858