



PRODUCT: _____

SKU NUMBER: _____

QUANTITY: _____



300-5020 2.2 gpm / 8.3 lpm @ 1100 psi / 76 bars

300-5021 2.9 gpm / 11 lpm @ 850 psi / 59 bars

FEATURES

- Thermal Relief Valve 120°F / 49°C Max Water Temp
- Powder Coated Gun Hanger
- Chemical Basket
- Adjustable Single Chemical Injection
- 35 ft GFCI Power Cord
- 30 ft Steel Braided High Pressure Hose
- 36 in Stainless Spray Gun and Wand Assembly
- 3 Cylinder CAT® SuperFlow Plunger Pump
- Industrial 2HP Totally Enclosed Motor & Fan Cooled
- 115 Volt / 60Hz / 1 phase / 15 Amps
- 850 psi / 2.9 gpm
- 1100 psi / 2.2 gpm

SMT - 1100PE Portable Cleaning System

Spray Master Technologies®

TOLL FREE: 800.548.3373

115 E. LINDEN, ROGERS, ARKANSAS 72756 USA

PHONE: +1 479.636.5776

FAX: +1 479.636.3245

WWW.SPRAYMASTERTECH.COM



SMT - 1100PE Portable Cleaning System

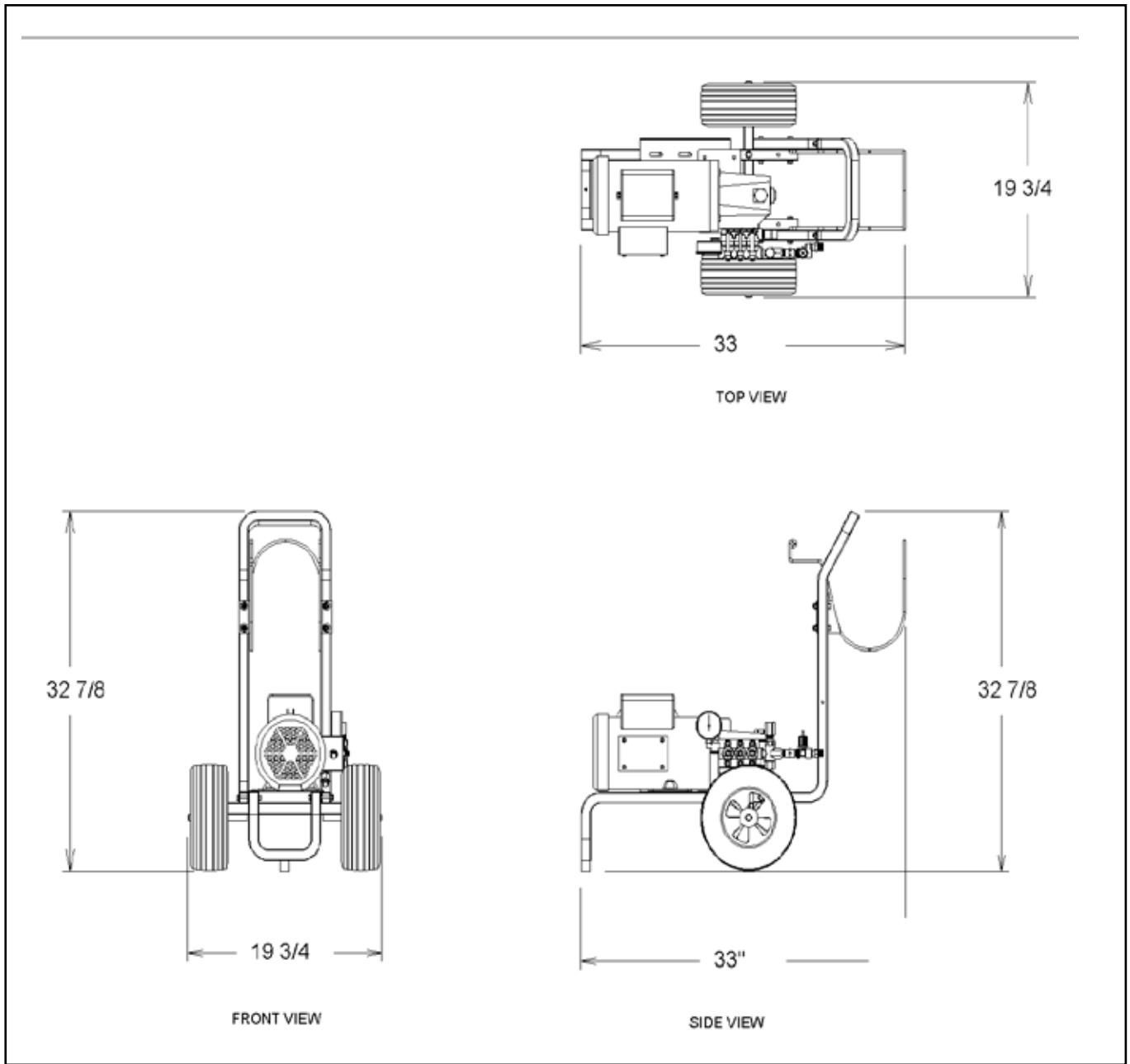

Equipment Specifications

Plumbing

3/4 in / 2 cm Hose Bib with 5 gpm / .14 lpm @ 30 psi / 20.6 bars. 120°F / 49°C Max

Electrical

115V, 16A Dedicated Circuit