



PRODUCT: \_\_\_\_\_

SKU NUMBER: \_\_\_\_\_

QUANTITY: \_\_\_\_\_



300-5050 2.2 gpm / 8.3 lpm @ 1100 psi / 76bars

300-5051 2.9 gpm / 11 lpm @ 850 psi / 59bars

## FEATURES

- Thermal Limit Switch 120°F / 49°C Max Water Temp
- Manual Rewind Hose Reel
- Stainless Steel Gun Hanger
- Dual Chemical Selection
- 35 ft GFCI Power Cord
- 30 ft Steel Braided High Pressure Hose
- 36 in Stainless Spray Gun and Wand Assembly
- 3 Cylinder CAT® SuperFlow Plunger Pump
- Industrial 2HP Totally Enclosed Motor & Fan Cooled
- 115 Volt / 60Hz / 1 phase / 15 Amps
- 850 psi / 2.9 gpm
- 1100 psi / 2.2 gpm

SMT - 600PEW Portable System

**Spray Master Technologies®**

**TOLL FREE: 800.548.3373**

115 E. LINDEN, ROGERS, ARKANSAS 72756 USA

PHONE: +1 479.636.5776

FAX: +1 479.636.3245

**WWW.SPRAYMASTERTECH.COM**



# SMT - 600PEW Portable System

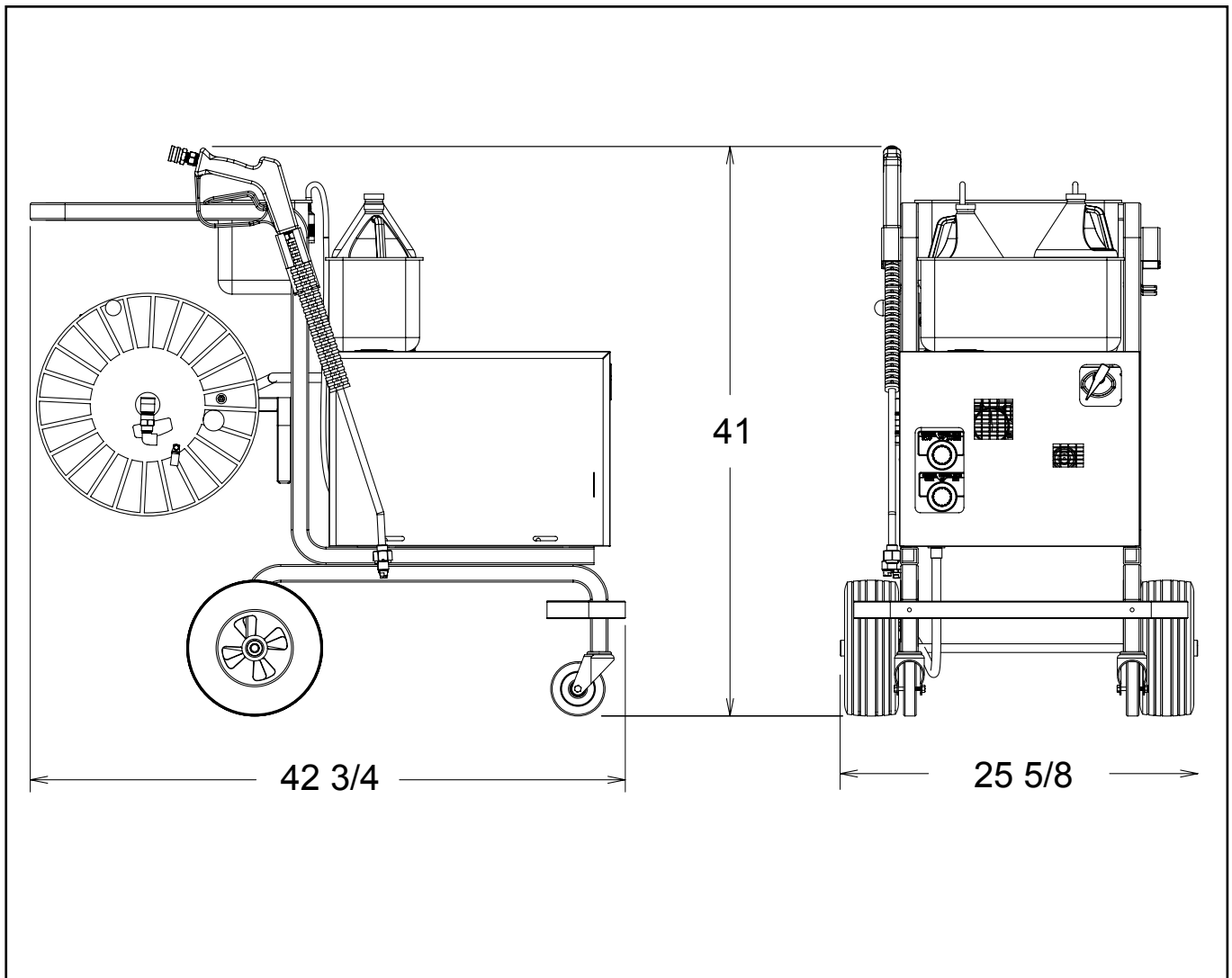

## Equipment Specifications

### Plumbing

3/4 in / 2 cm Hose Bib with 5 gpm / .14 lpm @  
30 psi / 20.6 bars. 120°F / 49°C Max

### Electrical

115V, 16A Dedicated Circuit