



SPT-93 SATURN STAINLESS STEEL COMMERCIAL PIZZA PREP TABLE



FEATURES:

- Stainless steel exterior
- Stainless steel interior
- Easy grab recessed door handles
- Stainless steel lid installed
- Large removable cutting board
- Environmentally friendly R-134A refrigeration
- Manual temperature control
- Magnetic gaskets installed on doors
- Twin epoxy coated shelves per door section
- Ready to plug in with a 115V / 60 Hz / 1Ph Nema 5-15P
- Four 5" casters (Two front casters include locking brakes)

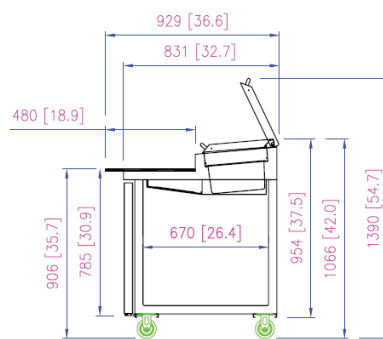
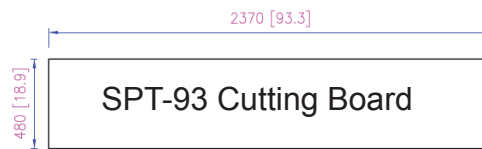
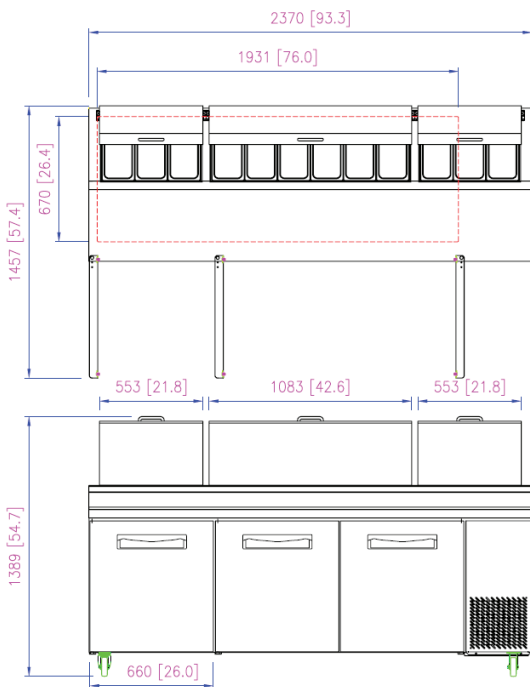

• Appliances must be installed with legs of a minimum height of 4"

Warranty: 1 year parts and labor. 5 year compressor.

SPT-93 COMMERCIAL STAINLESS STEEL PIZZA PREP TABLE												
Model	# of Doors	Capacity (Cu.Ft.)	# of Shelves	# of Pans	Power	Hz	Amps	HP	Weight	Length	Depth	Height
SPT - 93	3	33 cu.ft.	6	12	115 V	60	7.5	1/2	509 lbs	93.3"	36.6"	42"

*Note: Pans not included

* In the pursuit of a better product, durability and performance. SATURN reserves the right to change specifications, materials and design without further notice.

Tel: 303-801-0680 Fax: 303-801-0681 info@saturnequipment.com www.saturnequipment.com