



New **STAR-MAX® ELECTRIC CHAR-BROILERS**
Models 5124CF & 5136CF

Features/Benefits:

- ★ Star-Max® electric char-broilers are designed for the most demanding foodservice applications while providing years of maintenance free operation.
- ★ Available in 24" and 36" widths to fit many foodservice operation's space requirements.
- ★ *NEW* longer lasting, heavy-duty metal knobs.
- ★ Two types of heat transfer, radiation direct from elements and conduction through the grates, provide even heat distribution for maximum cooking performance.
- ★ High performance, incoloy sheath type heating elements, 4 on the 24" model and 6 on the 36" model, provide high speed char-broiling to accommodate high volume operations.
- ★ Infinite control every 12" of cooking surface for precise temperature control.
- ★ Heavy-duty cast iron grates are removable for fast and easy clean up.
- ★ Double wall construction and enclosed bottom helps reduce heat loss.
- ★ Swing-up heating element assembly can be locked in a vertical position for easy and safe cleaning.
- ★ Removable water pan prevents excessive flair ups for safe operations.
- ★ Cool-to-the-touch stainless steel bull nose front provides knob protection and a comfortable work zone.
- ★ Heavy-duty 4" adjustable legs to match the height of other Star-Max equipment in your line.



Model 5124CF

Applications:

Star-Max® electric char-broilers are designed for high volume and reliability. Whether it's steak, chicken, hamburger, shish kabobs or other menu items; Star-Max char-broilers will fulfill your menu requirements and more!

Quality Construction:

Star-Max® electric char-broilers are constructed of polished stainless steel and feature a 1" stainless steel wrap around splash guard, double wall aluminized steel side panels, stainless steel front control panel and stainless steel bull nose front. Units operate on 208V or 240V 1 phase and 3 phase with 1-3/8" diameter hole in bottom rear panels allow for 1 phase & 3 phase conduit.

New **Warranty:**

Star-Max® electric char-broilers are covered by Star's **TWO YEAR** parts and labor warranty.



*5136CF ONLY





New

STAR-MAX® ELECTRIC CHAR-BROILERS

Models 5124CF & 5136CF

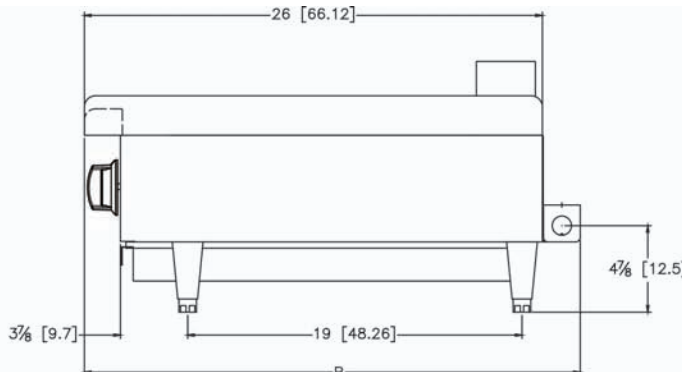
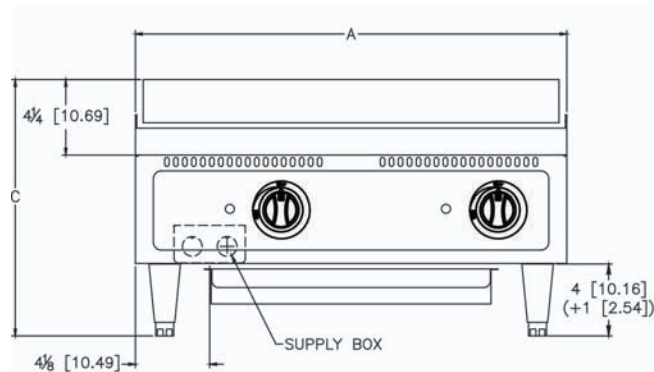

Performance Data

Model No.	Pre-Heat Time	4 oz. 4" diameter hamburgers per load
5124CF	8 to 10 Minutes	24
5136CF	8 to 10 Minutes	36

Specifications

Model No.	Dimensions			No. Controls	Grate Area	Approximate Weight	
	(A) Width Inches (cm)	(B) Depth Inches (cm)	(C) Height Inches (cm)			Installed lbs. (kg)	Shipping lbs. (kg)
5124CF	24 (61.0)	25-5/8 (65.0)	14-1/4 (36.2)	2	396 sq. in.	98 (45.0)	124 (55.8)
5136CF	36 (91.0)	25-5/8 (65.0)	14-1/4 (36.2)	3	594 sq. in.	175 (80.0)	186 (83.7)

Electrical Data

Model No.	Rated Wattage	Nominal Amps Per Line Wire							
		208V - 3 PH			240V - 3 PH			208V	240V
		X	Y	Z	X	Y	Z	1 PH	1 PH
5124CF	6600	21.8	21.8	13.8	18.8	18.8	11.9	31.8	27.5
5136CF	9900	27.6	27.6	27.6	23.9	23.9	23.9	47.6	41.3

Typical Specifications

Char-broilers are constructed of stainless steel and have a 6 qt. stainless steel water pan drawer on 24" models and a 9 qt. stainless steel water pan drawer on 36" models. Units feature heavy-duty cast iron grid sections and incoloy sheath-type heating elements. Char-broilers have an infinite control for every 12" of cooking surface. Units operate on 208 or 240 volts and have a rated wattage of 6,600 on 24" models and 9,900 on 36" models. Char-broilers are supplied with 4" (10.2 cm) high die cast nickel plated legs with a 1-3/8" (3.5 cm) adjustment. Bottom rear panels supplied with 1-3/8" diameter hole for installation of electrical conduit. Char-broilers are approved by Underwriter's Laboratories and ISO listed by UL Sanitation. Printed in the U.S.A.

Due to periodic changes in designs, methods, procedures, policies and regulations, the specifications contained in this sheet are subject to change without notice. While Star Manufacturing exercises good faith efforts to provide information that is accurate, we are not responsible for errors or omissions in information provided or conclusions reached as a result of using the specifications. By using the information provided, the user assumes all risks in connection with such use.