



New **STAR-MAX® ELECTRIC GRIDDLES** **Models 515TGF, 524TGF, 536TGF & 548TGF**

Features/Benefits:

- ★ *NEW* highly polished 1" thick polished steel plate for superior heat distribution, fast recovery and energy efficient operation.
- ★ All stainless steel construction and front panel for long lasting attractive appearance and ease of cleaning.
- ★ *Snap-action* thermostat inserted into the griddle plate 5/16" from the cooking surface, adjusts from 150° to 450°F providing quick response to surface temperature change.
- ★ Star-Max® electric griddles provide superior cooking performance and reliability.
- ★ *NEW* longer lasting, heavy-duty metal knobs.
- ★ Available in 15", 24", 36" and 48" widths to meet your space and volume requirements.
- ★ A 4000 watt element every 12" of cooking surface eliminates hot spots and allows for fast recovery.
- ★ Double wall construction and enclosed bottom helps reduce heat loss.
- ★ Cool-to-the-touch stainless steel bull nose front provides knob protection and comfortable work zone.
- ★ Heavy-duty all-welded body construction with stainless steel front, bull nose and 4-1/2" high tapered splash guard.
- ★ Spatula wide 3-1/4" grease trough, grease chute and 4-1/2" high tapered splash guard for easy clean up.
- ★ Large 4-1/2 quart stainless steel grease drawer is standard.
- ★ Heavy-duty 4" legs adjust to match the height of other Star-Max equipment in your line.



Model 536TGF

Applications:

Star-Max® electric griddles provide precise temperature control and are a perfect addition to any food service operation. Whatever the product, Star-Max electric griddles will deliver performance and reliability.

Quality Construction:

Star-Max® electric griddles are constructed with quality and durability in mind. Stainless steel bull nose front for knob protection, and nickel-plated die-cast legs offer years of easy maintenance and outstanding performance. Double wall construction allows installation within 1" of combustible surface when your space is limited. Griddles operate on 208 or 240 volts and are equipped with a junction box at the rear for making electrical connections.

New Warranty:

Star-Max® electric griddles are covered by Star's **TWO YEAR** parts and labor warranty.





New **STAR-MAX® ELECTRIC GRIDDLES** Models 515TGF, 524TGF, 536TGF & 548TGF

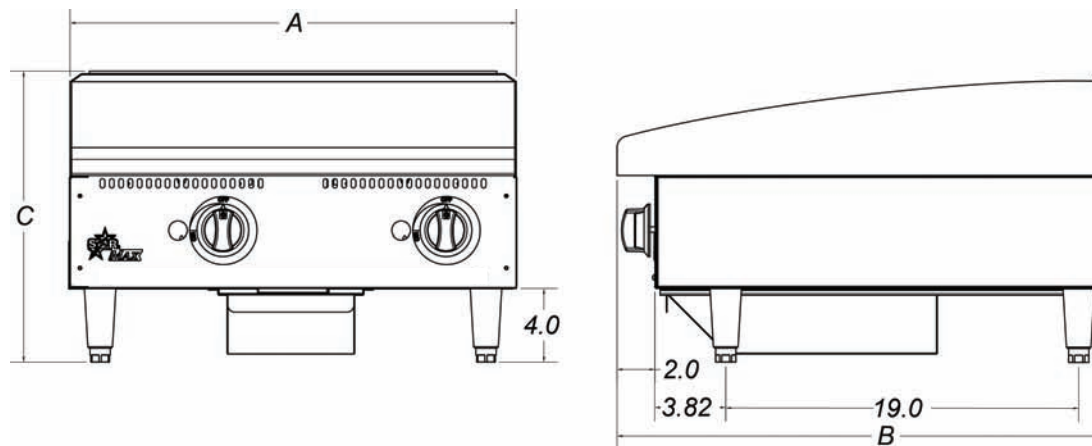

Specifications

Model No.	Dimensions				No. Controls	Grid Area	Plate Thickness Inches (cm)	Weight	
	(A) Width Inches (cm)	(B) Depth Inches (cm)	(C) Height Inches (cm)	(D) Leg Width Inches (cm)				Installed lbs. (kg)	Shipping lbs. (kg)
515TGF	15 (38.1)	27-7/8 (70.8)	15-1/2 (39.4)	12-3/4 (32.39)	1	304 sq. in. 1961.4 sq. cm	1" (2.5)	83 (37.6)	125 (56.7)
524TGF	24 (61.0)	27-7/8 (70.8)	15-1/2 (39.4)	20-3/4 (52.71)	2	498 sq. in. 3213.1 sq. cm	1" (2.5)	165 (74.8)	175 (79.4)
536TGF	36 (91.4)	27-7/8 (70.8)	15-1/2 (39.4)	32-3/4 (83.19)	3	747 sq. in. 4819.6 sq. cm	1" (2.5)	247 (112.0)	262 (118.9)
548TGF	48 (121.9)	27-7/8 (70.8)	15-1/2 (39.4)	44-3/4 (113.67)	4	996 sq. in. 6426.2 sq. cm	1" (2.5)	330 (149.7)	350 (158.8)

Electrical Data

Model No.	Rated Wattage		3 Phase Loading KW Per Phase						Nominal Amps Per Line Wire							
	208V	240V	208V			240V			208V-3PH			240V-3PH			208V 1PH	240V 1PH
			X-Y	Y-Z	X-Z	X-Y	Y-Z	X-Z	X	Y	Z	X	Y	Z		
515TGF	3,004	4,000			3			4							14.44	16.66
524TGF	6,008	8,000	3	3		4	4		14.4	25	14.4	16.7	28.9	16.7	28.9	33.3
536TGF	9,012	12,000	3	3	3	4	4	4	25	25	25	28.9	28.9	28.9		
548TGF	12,016	16,000	3	3	6	4	4	8	38.2	25	38.2	44.2	28.9	44.2	57.8	66.7

Typical Specifications

Electric griddles are constructed of stainless steel front panel and double wall aluminized steel side panels. Griddle plate is 1" thick highly polished steel with 4-1/2" (11.4 cm) wrap-around stainless steel splash guard. Unit has a 3-1/4" (8.3 cm) wide front grease trough with grease chute and 4-1/2 qt. (4.257 L) stainless steel grease drawer. Unit is heated with a 4000 watt incoloy sheath type element every 12" (30.48 cm) of griddle width and is controlled with a snap-action thermostat embedded into the griddle plate. Thermostat knob is protected by a stainless steel bull nose front. Units are supplied with 4" (10.16 cm) die cast nickel plated legs that have a 1-3/8" (3.5 cm) adjustment. A junction box is provided for making electrical connections. Units are listed by Underwriters Laboratories, and are UL Sanitation and CSA approved. Printed in the U.S.A.

Due to periodic changes in designs, methods, procedures, policies and regulations, the specifications contained in this sheet are subject to change without notice. While Star Manufacturing exercises good faith efforts to provide information that is accurate, we are not responsible for errors or omissions in information provided or conclusions reached as a result of using the specifications. By using the information provided, the user assumes all risks in connection with such use.