

COUNTER-TOP SHAKE OR SLUSH FREEZER

E112



- Compact, space-saver unit, offers the convenience to serve frozen beverages, shakes, smoothies or frozen cocktails.
- One selector switch, auto-off-clean, for simplified operation and cleaning.
- 6,000 Btu/hr compressor produces more finished product in a smaller footprint.
- Low mix warning light with electronic controls are auto-fill ready.
- Stainless stator auger, heavy duty speed reducer, 1/3 hp drive motor sets the standard for long life dependability.
- Stator bar agitates frozen beverage mixes with a wide range of sugar content (Brix measurement).
- Filtered bottom air inlet permits side by side installation with 4 inches of back air clearance.
- One piece clear polycarbonate door highlights pre-flavored products.
- Electric CO₂ or air operated autofill kits available.
- On demand defrost insures a smooth drink with consistent quality.
- Optional bottle rack with plastic bottles available.



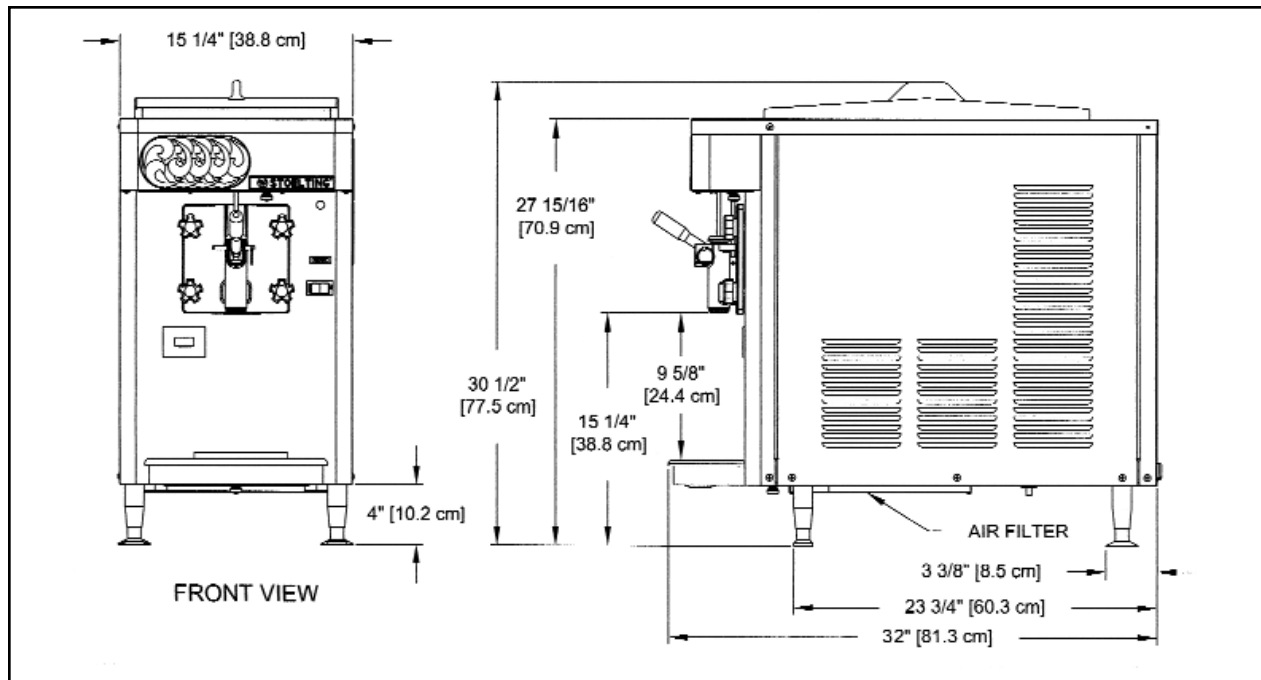

Model E112		
Dimensions	Machine	with crate
width	15-1/4" (38,7 cm)	17-1/2" (44,5 cm)
height	30-1/2" (77,5 cm)	35" (88,9 cm)
depth	32" (81,3 cm)	36-1/2" (92,7 cm)
Weight	205 lbs (92,9 kg)	215 lbs (97,5 kg)
Electrical	1 Phase, 115 VAC, 60Hz	
running amps	approximately 16A	
connection type	NEMA5-20P power cord provided	
International Option	1 Phase, 220-240 VAC, 50Hz	
Compressor	6,000 Btu/hr	
Drive Motor	1/3 hp	
Air Flow	Air cooled units require 3" (7,6 cm) air space on both sides or 4" (10,2 cm) air space in back for side-by-side installation	
Hopper Volume	3.625 gallon (13,73 liters)	
Freezing Cylinder Volume	1.25 gallon (5 quart), 4,73 liters	

Continuous research leads to ongoing product improvements; therefore, these specifications are subject to change without notice.

Distributed by:



FOODSERVICE EQUIPMENT
 502 Highway 67 • Kiel, WI 53042-1600
 920-894-2293 • 800-558-5807
 Fax: 920-894-7029
 E-mail: foodservice@stoelting.com
 www.stoeltingfoodservice.com

ISO 9001:2000 Registered

Certified, Listed and/or Recognized by:

