

BATCH FREEZER

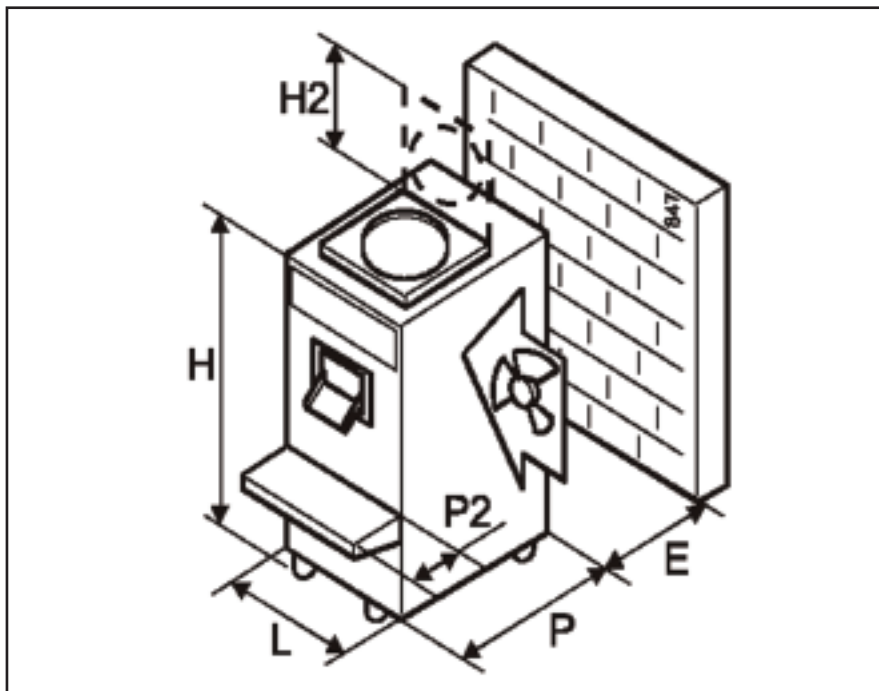

- Vertically oriented freezing cylinder provides high capacity, and maximum energy efficiency.
- Large diameter freezing cylinder facilitates extremely fast freezing times, resulting in very small ice crystal formation.
- Easy cleaning and simple assembly of beater parts.
- Low cost, long wearing, NSF approved plastic beater blades minimize frequent and costly blade replacement.
- Heavy-duty stainless steel beater shaft built to withstand years of use.
- Clear acrylic freezing cylinder cover allows monitoring of product while freezing.
- Easy access to freezing cylinder when adding variegates and particulates.
- Thorough mixing of variegates and particulates unachievable to horizontal barrels.
- All controls and indicators conveniently grouped in a single panel, on the front of the freezer.
- All buttons and indicators identified by easily understood symbols relative to their function.
- Time controlled freezing cycle achieves smooth texture and product consistency.
- Swing gate style, stainless steel extraction door design provides rapid extraction of product.



SPECIFICATIONS	MODEL VB9	
DIMENSIONS	FREEZER	WITH CRATE
Depth (P)	20" (51 cm)	23" (59 cm)
Width (L)	16" (41 cm)	19" (49 cm)
Height (H)	25" (64 cm)	35" (89 cm)
	(H2) Door Clearance (on top of freezer): 12.2" (44cm)	
WEIGHT	FREEZER	WITH CRATE
	143 lbs. (65kg)	179 lbs. (81 kg)
ELECTRICAL	1 phase, 115 volt, 1.5 kW, 60 Hz Approximately 15 total running amps. 20 amp fuse, HACR circuit breaker or regular circuit breaker.	
REFRIGERANT	R404A HFC environmentally friendly refrigerant	
COMPRESSOR	0.6 H.P. hermetic	
BEATER MOTOR	1.33 H.P.	
COOLING / AIR FLOW (E), (H2)	Air-Cooled. Right to left air flow. Units require 4" (10 cm) minimum clearance on both sides and back of unit.	
CYLINDER CAPACITY	1.75 gallons (7 quarts, 6.62 liters)	
LIQUID MIX PER BATCH	1 minimum, 2 maximum Quarts	
WORKING CYCLE	Approximately 15 minutes	
HOURLY PRODUCTION	9 Quarts (on average)	
WARRANTY	One-year parts and labor warranty. Two-years parts warranty on freezing cylinder, compressor, drive motor, gearbox, and agitator shaft.	

Continuous research leads to ongoing product improvements; therefore, these specifications are subject to change without notice.

Distributed by:



STOELTING®

FOODSERVICE EQUIPMENT

502 Highway 67 • Kiel, WI 53042-1600

920-894-2293 • 800-558-5807

Fax: 920-894-7029

E-mail: foodservice@stoelting.com

www.stoeltingfoodservice.com

ISO 9001:2000 Registered

Certified, Listed and/or Recognized by:

