

Product Specifications

Refrigerated Self-Service Dual Sided Island With Ambient Shelving

FSI23R

Lengths include end panels
 38-1/2"L x 30-1/4"D x 38-1/4"H



STD = W/o Shelves On Ends



OPT = W/ Shelves On One End



OPT = W/ Shelves On Both End



STANDARD FEATURES

- Breeze~E (Type-II) w/ EnergyWise s/c refrigeration
- Casters w/ levelers
- Compressor air intake in one side & out other side. All louvered panels cannot be blocked
- Integrated average product temperature of 40°F or less
- LED 3500K top & nose lights
- Metal shelves, non-lighted (refrigerated section)
- One year parts & labor; 5 year compressor warranty
- Price tag moulding (refrig section) (matches interior color)
- Removable deck pans provide complete access to evaporator coil & refrigeration connections

Features	Standard	Options
EXTERIOR COLOR	<input type="checkbox"/> Laminated (non-premium) Confirm pattern/grain direction	<input type="checkbox"/> Laminated (premium) Confirm pattern/grain direction <input type="checkbox"/> Stainless steel (includes lower front panel)
INTERIOR COLOR	<input type="checkbox"/> Black	<input type="checkbox"/> Stainless steel
LOWER FRONT PANEL COLOR	<input type="checkbox"/> Black	<input type="checkbox"/> Stainless steel (w/stainless ext. only)
ENDS	<input type="checkbox"/> Full end panel w/mirror interior (laminated) (metal edge matches interior color)	<input type="checkbox"/> (1) slat wall end w/mirror interior & (4) non-lighted shelves (black) <input type="checkbox"/> (1) slat wall end w/mirror interior & (4) non-lighted shelves (stainless) <input type="checkbox"/> (2) slat wall ends w/mirror interior & (4) non-lighted shelves (black) <input type="checkbox"/> (2) slat wall ends w/mirror interior & (4) non-lighted shelves (stainless)
ELECTRICAL CONNECT	<input type="checkbox"/> 6' straight blade power cord (self-cont.)	<input type="checkbox"/> 6' locking power cord (self-cont.)
MISCELLANEOUS		<input type="checkbox"/> Second year parts & labor warranty (excludes compressor)

Product Specifications

Intended Environment: Type I - Designed to operate in ambient conditions of 75°F with 55% relative humidity unless noted otherwise in system information below.	
Zone	Intended Product To Be Displayed
All	Packaged refrigerated products
Integrated Prod Temp ° F	
40	

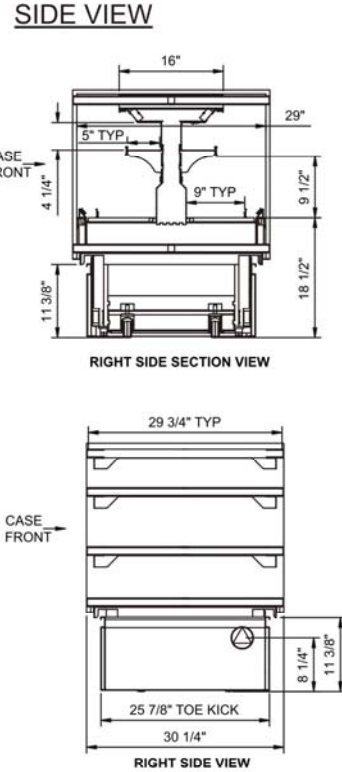
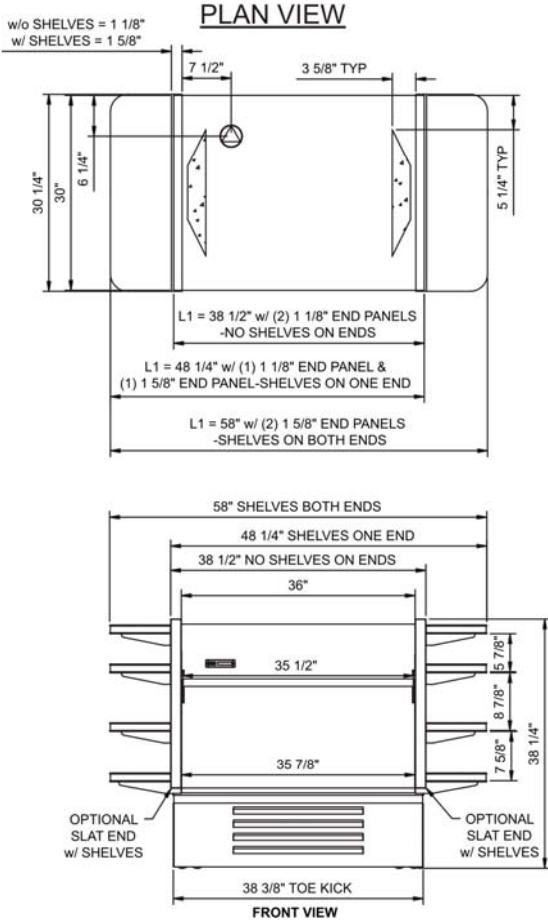

- NOTE: ALL DIMENSIONS APPROXIMATE**
- ELECTRICAL JUNCTION BOX (SUPPLIED WITH 6\"/>
 - LOCATION OF DRAIN TUBE FOR REMOTE REF. ONLY (SUPPLIED WITH 3/4\"/>
 - REFRIGERATION LINE CONNECTION.
 - REMOTE FLOOR SINK & UTILITIES ACCESS AREA.
 - SELF-CONTAINED CASE SERVICE ACCESS AREA.
 - DRY CASE SERVICE ACCESS AREA.

Model Technical Specifications															
Model	L"	L1"	L2"	System Circuit Volts		Phs	Freq	Amps ***	Watts	Wires	NEMA Plug	SST	BTUH	Ship Wt	
FSI23R	N/A	38.50	.00	Self-Contained	Circuit #1	110-120	1	60	14.20	1,231	2+G	5-20P or L5-20P	N/A	N/A	500

*** Does not include electric defrost on freezer models.

Important Notes:

- 1) ELECTRICAL NOTE: If GFCI is required, a GFCI breaker MUST be used in lieu of a GFCI receptacle
- 2) Units are supplied with levelers. They must be adjusted during installation to ensure the unit is level and plumb. Dimensions reflect levelers extended 1 1/4".

Regulatory Approvals:

All Models	Accordance with AHRI Std 1200 ETL Listed to UL 471 ETL Listed to CAN/CSA 22.2 No. 120 ETL Sanitation to NSF 7
------------	------------------------------------------------------------------------------------------------------------------------

