

## Product Specifications

### Refrigerated Prep Case with Refrigerated Rear Storage

Lengths include end panels

- FSPS48
- FSPS72

48-1/8"L x 39-3/4"D x 42-1/4"H  
 72-1/8"L x 39-3/4"D x 42-1/4"H



MODEL SHOWN: FSPS72

NOTE: INTERIOR PANS NOT PROVIDED W/CASE  
 FSPS48 HOLDS (3) FULL SIZE 4"D PANS - FSPS72 = (5)

#### STANDARD FEATURES

- Breeze™ w/EnergyWise s/c refrigeration
- Casters w/ levelers (n/a w/ remote ref.)
- Compressor air intake from rear and out front panel at toe kick. Front panel cannot be blocked.
- Condiment pan support rails
- Curved single pane, lift-up front glass w/o lock
- Integrated average product temperature of 40°F or less
- NOTE: Pans not supplied with case.
- NOTE: Remote only available w/rail base w/shims. N/A w/ levelers, casters or legs.
- One year parts & labor; 5 year compressor warranty
- Refrigerated rear storage (w/doors)
- Stainless steel Interior

Features	Standard	Options
<b>EXTERIOR COLOR</b>	<input type="checkbox"/> Laminated (non-premium) Confirm pattern/grain direction	<input type="checkbox"/> Laminated (premium) Confirm pattern/grain direction <input type="checkbox"/> Stainless steel
<b>TRIM COLOR</b>	<input type="checkbox"/> Black	<input type="checkbox"/> Silver
<b>REAR WORK LEDGE</b>	<input type="checkbox"/> White Sanalite®	<input type="checkbox"/> Richlite®
<b>TOE KICK</b>	<input type="checkbox"/> Painted - Black	<input type="checkbox"/> Stainless steel
<b>ELECTRICAL CONNECT</b>	<input type="checkbox"/> 6' straight blade power cord (self cont.)	<input type="checkbox"/> 6' locking power cord (self cont.) <input type="checkbox"/> Electrical leads (remote)
<b>REFRIGERATION</b>	<input type="checkbox"/> Breeze™ w/EnergyWise s/c refrigeration	<input type="checkbox"/> NOTE: Remote only available w/rail base w/shims. N/A w/ levelers, casters or legs. <input type="checkbox"/> Note: Remote doesn't incl Conds unit. Floor drain reqd. <input type="checkbox"/> Remote w/thermostat, solenoid & TXV
<b>MISCELLANEOUS</b>		<input type="checkbox"/> Second year parts & labor warranty (excludes compressor)
<b>ACCESSORIES</b>		<input type="checkbox"/> Stainless steel condiment pans w/covers

## Product Specifications

<b>Intended Environment:</b> Type I - Designed to operate in ambient conditions of 75°F with 55% relative humidity unless noted otherwise in system information below.	
<b>Zone</b>	<b>Integrated Prod Temp ° F</b>
All	40

PLAN VIEW

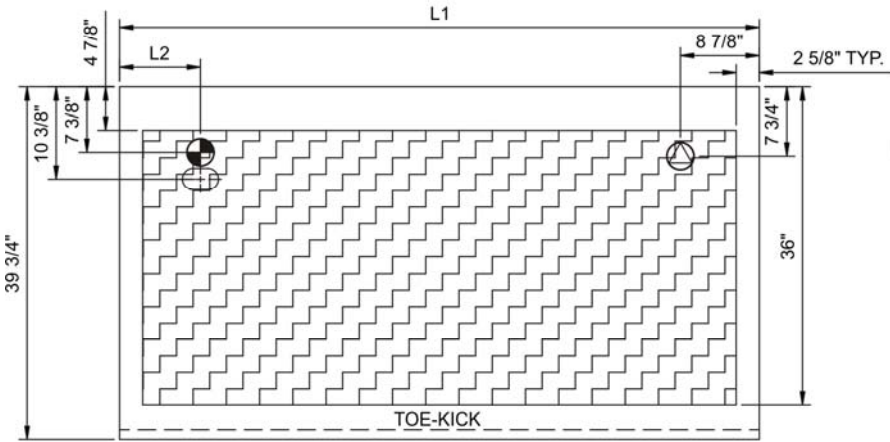

CASE FRONT

Note: Condensation may occur in operating conditions outside of the intended 75°F, 55% humidity conditions.

SIDE VIEW

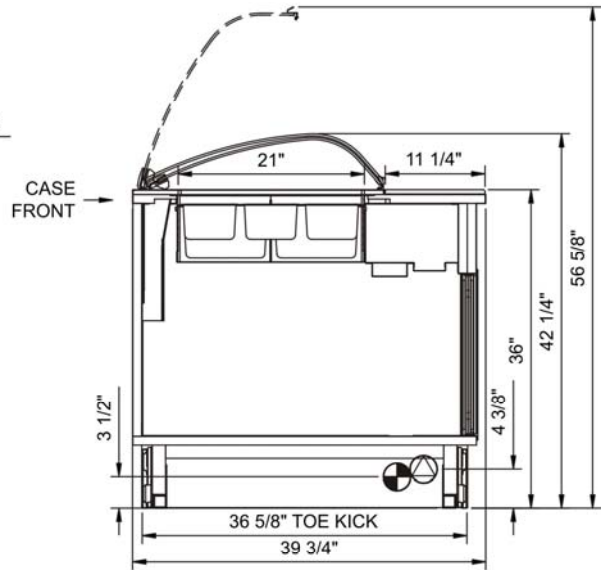

WELL CAPACITY	
PANS NOT PROVIDED WITH UNIT	
FSPS48	= 3-FULL SIZE 4\"/>
FSPS72	= 5-FULL SIZE 4\"/>

NOTE: ALL DIMENSIONS APPROXIMATE

- ELECTRICAL JUNCTION BOX (SUPPLIED WITH 6\"/>
- REFRIGERATION LINE CONNECTION.
- SELF-CONTAINED CASE SERVICE ACCESS AREA.
- LOCATION OF DRAIN TUBE FOR REMOTE REF. ONLY (SUPPLIED WITH 3/4\"/>
- REMOTE FLOOR SINK & UTILITIES ACCESS AREA.
- DRY CASE SERVICE ACCESS AREA.

Model Technical Specifications

Model	L"	L1"	L2"	System Circuit Volts		Phs	Freq	Amps ***	Watts	Wires	NEMA Plug	SST	BTUH	Ship Wt	Frt Cls	
FSPS48	N/A	48.13	9.13	Remote(Type I)	Circuit #1	110-120	1	60	1.17	116	2+G	Leads Multiple	20	1,400	1,000	110
				Self-Contained	Circuit #1	110-120	1	60	11.90	1,175	2+G	5-15P or L5-15P	N/A	N/A		
FSPS72	N/A	72.13	9.13	Remote(Type I)	Circuit #1	110-120	1	60	1.32	135	2+G	Leads Multiple	20	2,000	1,400	110
				Self-Contained	Circuit #1	110-120	1	60	13.80	1,327	2+G	5-15P or L5-15P	N/A	N/A		

\*\*\* Does not include electric defrost on freezer models.

Regulatory Approvals:	
All Models	Accordance with AHRI Std 1200 ETL Listed to UL 471 ETL Listed to CAN/CSA 22.2 No. 120 ETL Sanitation to NSF 7

Important Notes:

- 1) ELECTRICAL NOTE: If GFCI is required, a GFCI breaker MUST be used in lieu of a GFCI receptacle
- 2) Units are supplied with levelers. They must be adjusted during installation to ensure the unit is level and plumb. Dimensions reflect levelers extended 1 1/4".

