



Foodservice Equipment

Job \_\_\_\_\_ Item# \_\_\_\_\_

## Conveyor Toasters

### TCT1, TCT2 & TCT3

#### Standard Features:

- Forced convection system keeps the toaster cool to the touch and extends the life of critical components. The forced convection system increases productivity by circulating pre-heated air into toasting chamber.
- Quartz infrared heaters provide faster, more consistent heating than traditional heating elements.
- Compact design- requires only 14-1/4" of counter space and the forced convection system allows the unit to be placed against a wall. Other toasters have louvers requiring additional counter space.
- Steady production in a compact foot print. TCT1 toasts up to 350 slices per hour. TCT2 toasts up to 500 slices per hour. TCT3 toasts up to 600 bun halves per hour.
- Easy-to-use control panel takes the guesswork out of speed control settings.
- Variable speed control for perfect color and texture of bread, bagels, English muffins and more!
- Energy efficient operation with power saver switch reducing electricity consumption by 75%. And quartz heaters return to full power in seconds vs. minutes for metal-sheathed elements.
- Extended conveyor belt for easy loading and large warming area for higher production.
- Safe load up area with full width front burn guard and cool-to-the-touch exterior.
- "Smart" crumb tray keeps the bread crumbs from falling under the toaster.
- Heated holding area to keep toast at the perfect temperature.



TCT1

#### Applications:

Compact conveyor toasters have been designed and engineered for the budget minded small volume operation. Compact and versatile requiring minimal counter space and delivers perfect toast, bagels, buns, English muffins, frozen waffles and more for about the price of a pop up toaster.

#### Quality Construction:

Toastermaster designs every toaster to stand up to the most rigorous foodservice demands. Stainless steel construction for long lasting durability. Heavy-duty motor, drive chain and conveyor speed control for superior reliability. Conveyor belt tension system for smooth and quiet operation. High performance Quartz Infrared Heaters for superior toasting performance and reliability. Units are easy to disassemble with one-piece cover for cleaning and service. Toasters are furnished with 1" adjustable legs and 4' cord and a standard NEMA 5-15 plug for plug in installation in a grounded 120V outlet.

#### Warranty:

Toastermaster conveyor toasters are covered by a one-year parts and labor warranty.



# Conveyor Toasters

## TCT1, TCT2 & TCT3

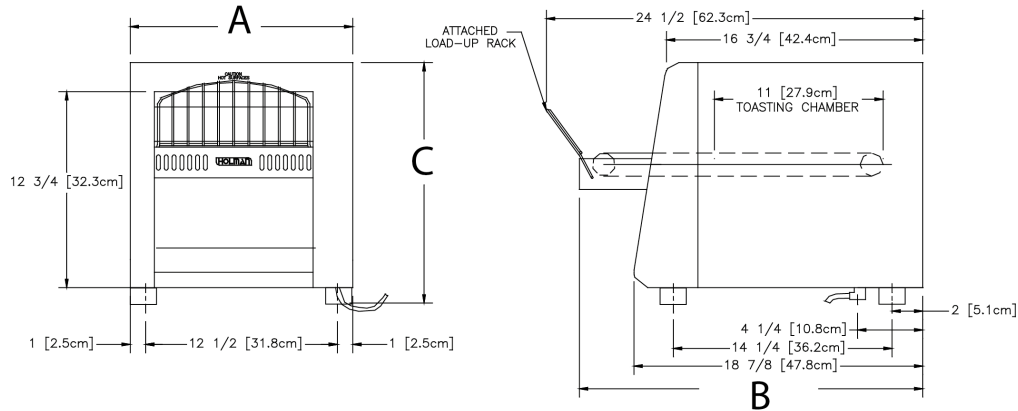

### Performance Data

Model No.	Production Capacities	Product Opening
TCT1	Up to 350 slices per hour	1-1/2"
TCT2	Up to 500 slices per hour	1-1/2"
TCT2	Up to 600 bun halves per hour	3"

### Specifications

Model No.	Dimensions			Shipping Weight lbs. (kg)	Shipping Carton		
	A Width Inches (cm)	B Depth Inches (cm)	C Height Inches (cm)		Width Inches (cm)	Depth Inches (cm)	Height Inches (cm)
TCT1	14-1/4" (36.2)	18-7/8" (47.9)	13-1/4" (33.6)	44 (20)	17-3/4" (45.1)	16-1/2" (41.9)	22" (55.9)
TCT2	14-1/2" (36.8)	22-3/8" (56.8)	15-5/8" (39.7)	64 (29)	20 (50.8)	18-7/8" (47.9)	25-3/8" (64.4)
TCT3	14-1/2" (36.8)	22-3/8" (56.8)	15-5/8" (39.7)	64 (29)	20 (50.8)	18-7/8" (47.9)	25-3/8" (64.4)

### Electrical Data

Model No.	Volts	HZ 1 Phase	Amps	Watts	Heating Elements		NEMA
					Above Belt	Below Belt	
TCT1	120	60	13.8	1600	2	2	5-15P
	120C	60	13.8	1600	2	2	5-20P
TCT2	120	60	14.2	1700	2	2	5-15P
	120C	60	14.2	1700	2	2	5-20P
TCT3	208	60	13.5	2800	2	2	6-20P
	240	60	11.7	2800	2	2	6-20P

### Typical Specifications

Compact conveyor toasters are constructed of corrosion resistant stainless steel. Supplied with heavy-duty motor, drive chain and fast heat up quartz infrared heaters. A conveyor belt tension system is supplied for a smooth, quiet operation. Units are supplied with variable speed control, power saver and high limit switch. Extended conveyor belt, crumb tray, heated holding area and full width burn guard are standard. Unit has a one-piece cover for easy access with 1" adjustable legs. Units are listed with UL, CUL and are UL certified to NSF4.

INTENDED FOR COMMERCIAL USE ONLY. NOT FOR HOUSEHOLD USE.

TM103S/1015



Toastmaster, in line with its policy to continually improve its product, reserves the right to change materials or specifications without notice. Such revisions do not entitle the buyer to corresponding changes, improvements, additions, or replacements for previously purchased equipment.



Toastmaster® 10 Sunnen Dr. St. Louis, MO 63143  
(P) 314-678-6347 • www.toastmastercorp.com