

Project	Quantity	Item #
Model Specified:		CSI Section 11400

## "W-Width" Reach-In Refrigerator-Freezer Models/Self-Contained



Model RDT132WUT-HHS  
(shown with optional left door hinging and casters)

### One, Two & Three Section Models, 32" Deep



Stainless Exterior  
& Interior

2-Section Full Length Door Model	RDT232WUT-FHS
3-Section Full Length Door Model	RDT332WUT-FHS
1-Section Half Length Door Model	RDT132WUT-HHS
2-Section Half Length Door Model	RDT232WUT-HHS
3-Section Half Length Door Model	RDT332WUT-HHS



Stainless Exterior,  
Anodized Aluminum Interior

2-Section Full Length Door Model	ADT232WUT-FHS
3-Section Full Length Door Model	ADT332WUT-FHS
1-Section Half Length Door Model	ADT132WUT-HHS
2-Section Half Length Door Model	ADT232WUT-HHS
3-Section Half Length Door Model	ADT332WUT-HHS

The R & A Series represent Traulsen's Top-of-the-Line product offering. The "W-Width" reach-in refrigerator/freezer models are all designed to offer maximum interior storage capacity. Each is supplied standard with such high quality features as balanced refrigeration systems, microprocessor controls, communications ability and stainless steel exteriors. Additionally, they offer the widest range of optional accessories to choose from, and can be specified for use with many different applications, including: Foodservice, Correctional, Institutional, Export, etc.

## Standard Product Features

- R-Series: Stainless Steel Exterior & Interior
- A-Series: Stainless Steel Exterior/Anodized Aluminum Interior
- INTELA-TRAUL® Microprocessor Control System
- Balanced, Self-Contained Refrigeration Systems
- Scroll Blower Type Evaporator Fan (2 & 3 section models only)
- Biased Return Air Duct
- Full or Half Length Stainless Steel Doors With Locks (full-length doors n/a on one-section models)
- Self-Closing Doors With Stay Open Feature At 120 Degrees
- Guaranteed For Life Cam-Lift Hinges
- Guaranteed For Life Horizontal Work Flow Door Handle
- Standard Door Hinging: 132W = Right, 232W = Left/Right, 332W = Left/Right/Right (other hings available)
- Automatically Activated Incandescent Lights
- Stainless Steel Breaker Caps
- Adjustable Wire Shelves (installed at the factory)
- Automatic Non-Electric Condensate Evaporator (2 & 3 section models only)
- Magnetic Snap-In Door Gaskets
- Gasket Protecting Metal Door Liner
- Controllable Anti-Condensate Door Perimeter Heaters
- Thermostatic Expansion Valve Metering Device
- Stainless Steel One-Piece Louver Assembly
- 9' Cord & Plug Attached (1 & 2 section models only)
- Set of Four (4) 6" High Adjustable Stainless Steel Legs
- One Year Parts And Labor Warranty
- Two Year Control Warranty (parts and labor)
- Five Year Compressor Warranty

## Options & Accessories

- Stainless Steel Finished Back With Rear Louvers
- Re-Hinging Feature For Door(s)
- No. 1 Type Tray Slides To Accommodate either (1) 18" x 26" or (2) 14" x 18" Sheet Pans, Adjustable To 2" O.C.
- No. 2 Type Tray Slides To Accommodate (1) 18" x 26" Sheet Pans, Adjustable To 2" O.C.
- No. 3 Type Tray Slides To Accommodate (2) 12" x 20" Steam Table Pans, Adjustable To 2" O.C.
- No. 4 Type Tray Slides To Accommodate (1) 18" x 26" Sheet Pans (chrome rod type, equips 1/2 section)
- Universal Type Tray Slides To Accommodate Either (1) 18" x 26" or (2) 14" x 18" Sheet Pans, or (2) 12" x 20" Steam Table Pans, Adjustable To 4" O.C.
- Additional Wire Shelves
- Locking Hasps (padlocks supplied by others)
- Export 220/50/1 Voltage
- 208/115/60/1 Voltage In Lieu Of Standard 115/60/1
- Stainless Steel Shelves
- Kool Klad Exterior Laminate Decor
- Set of Four (4) 6" or 4-5/8" High Casters In Lieu of Legs
- 4-1/2" High Stainless Steel Base In Lieu of Legs
- 6" High Stainless Steel Kickplate (for use with standard legs)
- Prison/Correctional Facilities Options
- Remote Applications (see spec sheet TR35837 for details)
- Clear Glass Door(s) In Place Of One Or More Refrigerator Section Door(s)
- Water Cooled Self-Contained Condenser Suitable For Connection To Glycol
- Two Year Service/Labor Warranty Available



Listed by Underwriters Laboratories Inc.,  
to U.S. and Canadian safety standards and  
Listed by NSF International.

Approval: \_\_\_\_\_



TRAULSEN  
4401 BLUE MOUND RD.  
PHONE 1 (800) 825-8220  
Website: www.traulsen.com

FT. WORTH, TX 76106  
FAX-MKTG. 1 (817) 624-4302

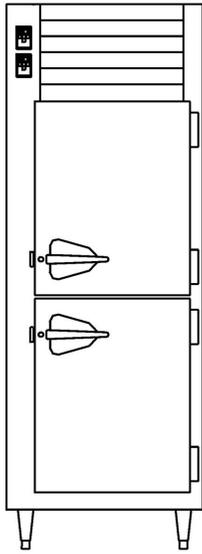

Elevation - R/ADT132WUT

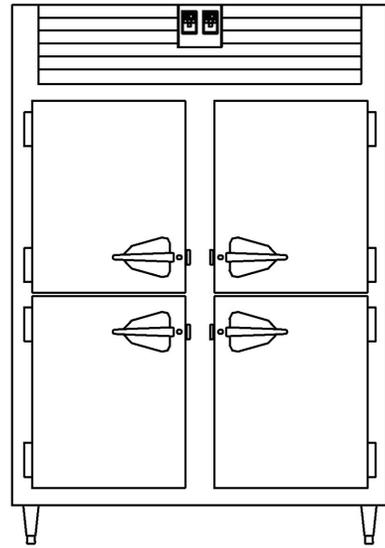

Elevation - R/ADT232WUT

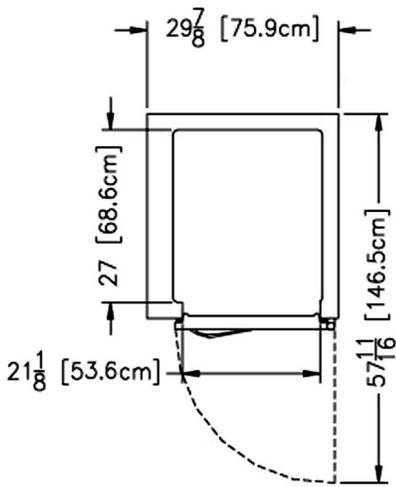

Plan - R/ADT132WUT

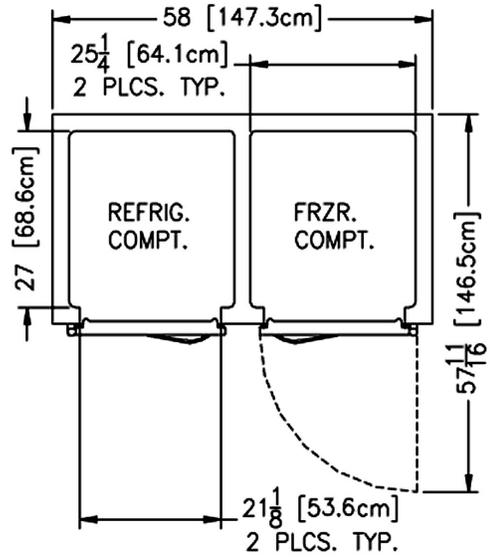

Plan - R/ADT232WUT

Section -  
R/ADT132WUT

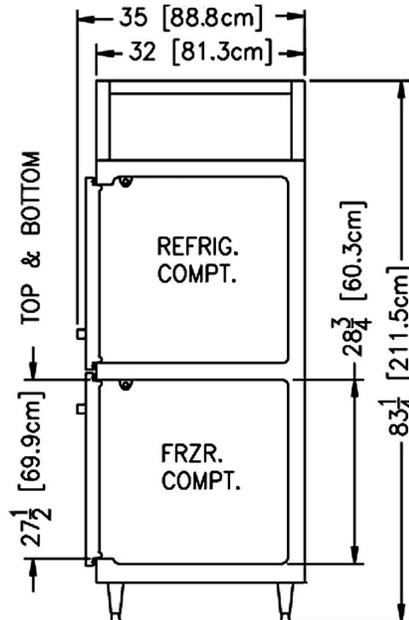

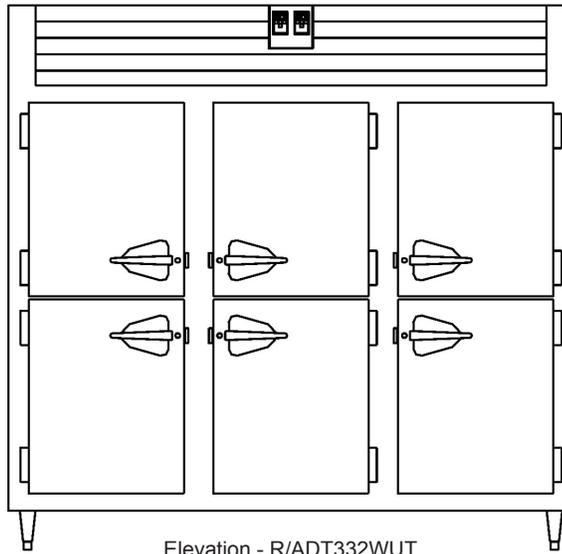

Elevation - R/ADT332WUT

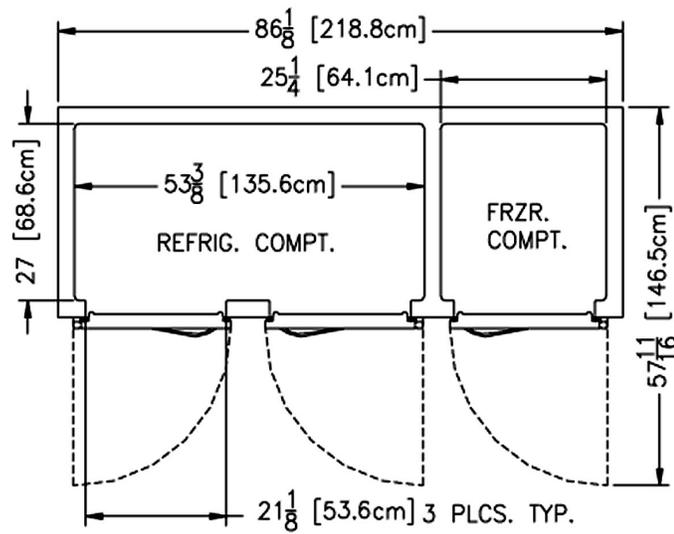

Plan - R/ADT332WUT

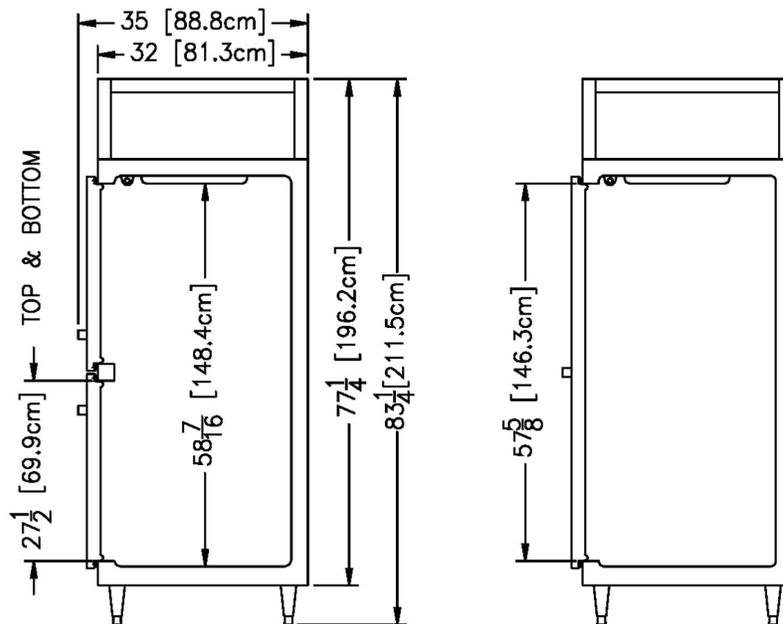

Section -  
 2 & 3 Section Models



TRAUlsen  
 4401 BLUE MOUND RD.  
 PHONE 1 (800) 825-8220  
 Website: www.traulsen.com

FT. WORTH, TX 76106  
 FAX-MKTG. 1 (817) 624-4302

Project	Quantity	Item #
Model Specified:		CSI Section 11400

## Specifications

### Construction, Hardware and Insulation

Cabinet exterior front, sides, louver assembly and doors are constructed of 20 gauge stainless steel with #4 finish. Cabinet interior and door liners are constructed of stainless steel (anodized aluminum in the A-Series). The exterior cabinet top, back and bottom are constructed of heavy gauge aluminumized steel. A set of four (4) adjustable 6" high stainless steel legs are included.

Doors are equipped with a gasket protecting metal door pan, removable plug cylinder locks and guaranteed for life cam-lift, gravity action, self-closing metal, glide hinges with stay open feature at 120 degrees. Hinges include a concealed switch to automatically activate the interior incandescent lighting. Guaranteed for life, work flow door handles are mounted horizontally over recess in door which limits protrusion from door face into aisles. Doors have seamless, polished metal corners.

Easily removable for cleaning, vinyl magnetic door gasket assures tight door seal. Anti condensate heaters are located behind each door opening.

Both the cabinet and door(s) are insulated with an average of 2" thick high density, non-CFC, foamed in place polyurethane.

DIMENSIONAL DATA	R/ADT132WUT	R/ADT232WUT	R/ADT332WUT
Net capacity total cu. ft.	21.6 (612 cu l)	45.0 (1275 cu l)	69.3 (1962 cu l)
Net capacity refriger. cu. ft.	10.8 (306 cu l)	23.2 (657 cu l)	47.5 (1346 cu l)
Net capacity freezer cu. ft.	10.8 (306 cu l)	21.8 (657 cu l)	21.8 (657 cu l)
Length - overall in.	29 <sup>11</sup> / <sub>16</sub> (75.9 cm)	58 (147.3 cm)	86 <sup>1</sup> / <sub>2</sub> (218.8 cm)
Depth - overall in.	35 (88.8 cm)	35 (88.8 cm)	35 (88.8 cm)
Depth - over body in.	32 (81.3 cm)	32 (81.3 cm)	32 (81.3 cm)
Depth - door open 90° in.	57 <sup>11</sup> / <sub>16</sub> (146.5 cm)	57 <sup>11</sup> / <sub>16</sub> (146.5 cm)	57 <sup>11</sup> / <sub>16</sub> (146.5 cm)
Clear door width in.	21 <sup>1</sup> / <sub>2</sub> (53.6 cm)	21 <sup>1</sup> / <sub>2</sub> (53.6 cm)	21 <sup>1</sup> / <sub>2</sub> (53.6 cm)
Clear half-door height in.	27 <sup>1</sup> / <sub>2</sub> (69.9 cm)	27 <sup>1</sup> / <sub>2</sub> (69.9 cm)	27 <sup>1</sup> / <sub>2</sub> (69.9 cm)
Clear full-door height in.	n/a	57 <sup>5</sup> / <sub>8</sub> (146.3 cm)	57 <sup>5</sup> / <sub>8</sub> (146.3 cm)
Height - overall on 6" legs	83 <sup>3</sup> / <sub>4</sub> (211.5 cm)	83 <sup>3</sup> / <sub>4</sub> (211.5 cm)	83 <sup>3</sup> / <sub>4</sub> (211.5 cm)
No. Standard Shelves	2	6	9
Shelf area total sq. ft. <sup>1</sup>	7.5 (.7 sq m)	25.2 (2.4 sq m)	37.8 (3.6 sq m)
Shelf area refriger. sq. ft. <sup>1</sup>	3.75 (.35 sq m)	12.6 (1.2 sq m)	25.2 (2.4 sq m)
Shelf area freezer sq. ft. <sup>1</sup>	3.75 (.35 sq m)	12.6 (1.2 sq m)	12.6 (1.2 sq m)
RDT Net Wt. lbs. <sup>2</sup>	360 (163 kg)	705 (320 kg)	1030 (467 kg)
ADT Net Wt. lbs. <sup>2</sup>	310 (140 kg)	615 (279 kg)	900 (408 kg)
<b>ELECTRICAL DATA</b>			
Voltage	115/60/1	115/60/1	115/60/1
Feed wires with Ground	3	3	3
Full load amperes	10.3	16.0	21.6
<b>REFRIGERATION DATA<sup>3</sup></b>			
Refrigerant - Refrigerator	n/a	R-134a	R-134a
Refrigerant - Freezer	R-404A	R-404A	R-404A
BTU/HR H.P. - Refrigerator	n/a	1730 (¼ HP) <sup>4</sup>	4200 (½ HP) <sup>4</sup>
BTU/HR H.P. - Freezer	1930 (½ HP) <sup>5</sup>	2170 (½ HP) <sup>4</sup>	2160 (½ HP) <sup>4</sup>

### NOTES

NOTE: Figures in parentheses reflect metric equivalents.

- Area of standard shelf compliance only, does not include storage area of additional shelves or available on each compartment bottom.
- For approximate remote weights deduct 40 lbs. from respective net or gross weight. For other information on remote models, please refer to spec sheet TR35837.
- Note that single section models employ one compressor and two evaporator coils, data listed reflects total refrigerator/freezer system.
- Based on a 90 degree F ambient and 20 degree F evaporator for the refrigerated section and a 90 degree F ambient and -20 degree F evaporator for the freezer section
- Based on a 90 degree F ambient and -10 degree F evaporator.

### Refrigeration System - One Section Models

A top mounted, self-contained, balanced refrigeration system using R-404A refrigerant is conveniently located behind the one piece louver assembly. It features an easy to clean front facing condenser, thermostatic expansion valve, air-cooled hermetic compressor, side mounted blower coils, large, high humidity evaporator coils located outside the food zone, and a bottom mounted electric condensate evaporator.

A 9' cord and plug is provided standard. Standard operating temperatures are 34 to 38°F for the refrigerator compartment and 0 to -5°F for the freezer compartment.

### Refrigeration System - Two & Three Section Models

A top mounted, self-contained, balanced refrigeration system using R-134a and R-404A refrigerants is conveniently located behind the one piece louver assembly. It features an easy to clean front facing condenser, thermostatic expansion valve, air-cooled hermetic compressors, plenum effect blower coil, large, high humidity evaporator coil located outside the food zone and a top mounted non-electric condensate evaporator.

Biased return air duct protects against introduction of warm kitchen air, promoting even temperature maintenance and efficient operation.

A 9' cord and plug is provided standard on two section models. Standard operating temperatures are 34 to 38°F for the refrigerator compartment and 0 to -5°F for the freezer compartment.

### Controller

The easy to use water resistant INTELA-TRAUL® microprocessor control system is supplied standard. Unit is NAFEM Data Protocol communication (NDP) ready. Optional hardware required to be NDP compliant. Third party software required for network connection. It includes a 3-Digit LED Display, Fahrenheit or Celsius Temperature Scale Display Capability, and an RS485 data port. In addition it includes audio/visual alarms for: Hi/Lo Cabinet Temperature, Door Open, Clean Condenser, Evaporator Coil and Discharge Line Sensor Failures, and Power Supply Interruption. A separate control is provided for both the refrigerator and freezer compartments.

### Interior

Standard interior arrangements include three (3) wire shelves per section, mounted on shelf pins (one section models are supplied standard with two wire shelves). Shelves are full-width, and do not have any large gaps between them requiring the use of "bridge" or "junior shelves." Recommended load limit per shelf should not exceed 225 lbs. Optional tray slides may be purchased in combination with, or in lieu of these. Both standard and optional interior arrangements are completely installed at the factory.

### Warranties

Both a one year parts and labor warranty and a five year compressor warranty (self-contained models only) are provided standard. An optional 2<sup>nd</sup> year extended parts and labor warranty is also available. In addition the INTELA-TRAUL® controls are warranted by a two year parts and labor warranty.



Equipped With One NEMA 5-15 P Plug  
(1 section models only)



Equipped With One NEMA 5-20 P Plug  
(2 section models only)

NOTE: Full load amps and plug style may vary depending on electrical options chosen and condensing unit employed.

### REQUIRED CLEARANCES

In order to assure optimum performance, the condensing unit **MUST** have an adequate supply of air for cooling purposes. Therefore, the operating location must either have a minimum of 12" clearance overhead of the condensing unit or allow for unrestricted air flow at the back of the unit. Note that certain maintenance tasks are possible only through the left side panel on single section models, or from above on two and three section models.

NOTE: When ordering please specify: Voltage, Hinging, Door Size, Options and any additional warranties.

Continued product development may necessitate specification changes without notice.  
Part No. TR35779 (revised 1/10)

**TRAULSEN**  
4401 BLUE MOUND RD.  
PHONE 1 (800) 825-8220  
Website: [www.traulsen.com](http://www.traulsen.com)

FT. WORTH, TX 76106  
FAX-MKTG. 1 (817) 624-4302

# Remote Refrigeration Data

Refer to the below chart to determine the following remote characteristics: Voltage, Amps, BTU's, Refrigerant, and if the following components are included: Condensate Evaporator, Solenoid, Expansion

Model No.	Voltage	Amps	BTU @ 90°F Ambient and Evap. Temp.	Refrig't	Cond. Evap.	Solenoid	Exp. Valve	Temp Control
					Yes/No	Yes/No	Yes/No	
G10000, etc.	115/60/1	4.1	1520 @ +20°F Evap	R-134a	Yes	Yes	Yes	Microprocessor
G10002P, etc.	115/60/1	4.1	1520 @ +20°F Evap	R-134a	Yes	Yes	Yes	Microprocessor
G11000, etc.	115/60/1	4.1	2410 @ +20°F Evap	R-134a	Yes	Yes	Yes	Microprocessor
G11002P, etc.	115/60/1	4.1	2400 @ +20°F Evap	R-134a	Yes	Yes	Yes	Microprocessor
G12010, etc.	115/60/1	10.6	1930 @ -10°F Evap	R-404A	Yes	Yes	Yes	Microprocessor
G20000, etc.	115/60/1	5.2	2410 @ +20°F Evap	R-134a	Yes	Yes	Yes	Microprocessor
G20004P, etc.	115/60/1	5.2	2410 @ +20°F Evap	R-134a	Yes	Yes	Yes	Microprocessor
G21000, etc.	115/60/1	5.2	4160 @ +20°F Evap	R-134a	Yes	Yes	Yes	Microprocessor
G21004P, etc.	115/60/1	5.2	4160 @ +20°F Evap	R-134a	Yes	Yes	Yes	Microprocessor
G22010, etc.	115/60/1	13.2	3080 @ -10°F Evap	R-404A	Yes	Yes	Yes	Microprocessor
G30000, etc.	115/60/1	5.2	3780 @ +20°F Evap	R-134a	Yes	Yes	Yes	Microprocessor
G31010, etc.	115/60/1	13.2	4710 @ -10°F Evap	R-404A	Yes	Yes	Yes	Microprocessor
G31310, etc.	115/60/1	13.2	4710 @ -10°F Evap	R-404A	Yes	Yes	Yes	Microprocessor
G32000, etc.	115/60/1	5.2	5330 @ +20°F Evap	R-134a	Yes	Yes	Yes	Microprocessor
R/AHT132W	115/60/1	1.5	2400 @ +20°F Evap	R-134a	No	Yes	Yes	Intela-Traul
R/AHT132EW	115/60/1	1.5	2400 @ +20°F Evap	R-134a	No	Yes	Yes	Intela-Traul
R/AHT232W	115/60/1	2.0	4360 @ +20°F Evap	R-134a	No	Yes	Yes	Intela-Traul
R/AHT332W	115/60/1	2.5	4360 @ +20°F Evap	R-134a	No	Yes	Yes	Intela-Traul
R/AHT232N	115/60/1	2.0	4360 @ +20°F Evap	R-134a	No	Yes	Yes	Intela-Traul
R/AHT332N	115/60/1	2.5	4360 @ +20°F Evap	R-134a	No	Yes	Yes	Intela-Traul
R/AHT126W	115/60/1	1.5	2400 @ +20°F Evap	R-134a	No	Yes	Yes	Intela-Traul
R/AHT226W	115/60/1	2.0	2400 @ +20°F Evap	R-134a	No	Yes	Yes	Intela-Traul
R/AHT132D	115/60/1	1.5	2400 @ +20°F Evap	R-134a	No	Yes	Yes	Intela-Traul
R/AHT232D	115/60/1	2.0	4360 @ +20°F Evap	R-134a	No	Yes	Yes	Intela-Traul
R/AHT132WP	115/60/1	2.0	2400 @ +20°F Evap	R-134a	No	Yes	Yes	Intela-Traul
R/AHT232WP	115/60/1	2.5	4360 @ +20°F Evap	R-134a	No	Yes	Yes	Intela-Traul
R/AHT332WP	115/60/1	3.0	4360 @ +20°F Evap	R-134a	No	Yes	Yes	Intela-Traul
R/AHT232NP	115/60/1	2.5	4360 @ +20°F Evap	R-134a	No	Yes	Yes	Intela-Traul
R/AHT332NP	115/60/1	3.0	4360 @ +20°F Evap	R-134a	No	Yes	Yes	Intela-Traul
R/AHT126WP	115/60/1	2.0	2400 @ +20°F Evap	R-134a	No	Yes	Yes	Intela-Traul
R/AHT226WP	115/60/1	2.5	2400 @ +20°F Evap	R-134a	No	Yes	Yes	Intela-Traul
R/ALT132W	115/60/1	7.5	2160 @ -20°F Evap	R-404A	No	Yes	Yes	Intela-Traul
R/ALT232W	115/60/1	10.0	3790 @ -20°F Evap	R-404A	No	Yes	Yes	Intela-Traul
R/ALT332W	115/60/1	11.0	5220 @ -20°F Evap	R-404A	No	Yes	Yes	Intela-Traul
R/ALT232N	115/60/1	10.0	3790 @ -20°F Evap	R-404A	No	Yes	Yes	Intela-Traul
R/ALT332N	115/60/1	11.0	5220 @ -20°F Evap	R-404A	No	Yes	Yes	Intela-Traul
R/ALT126W	115/60/1	4.0	1980 @ -20°F Evap	R-404A	No	Yes	Yes	Intela-Traul
R/ALT226W	115/60/1	7.5	3790 @ -20°F Evap	R-404A	No	Yes	Yes	Intela-Traul
R/ALT132D	115/60/1	6.0	2160 @ -20°F Evap	R-404A	No	Yes	Yes	Intela-Traul
R/ALT232D	115/60/1	10.0	3790 @ -20°F Evap	R-404A	No	Yes	Yes	Intela-Traul
R/ARI132L	115/60/1	2.0	2400 @ +20°F Evap	R-134a	No	Yes	Yes	Intela-Traul
R/ARI232L	115/60/1	3.0	4360 @ +20°F Evap	R-134a	No	Yes	Yes	Intela-Traul
R/ARI332L	115/60/1	4.0	5330 @ +20°F Evap	R-134a	No	Yes	Yes	Intela-Traul
R/ARI132LP	115/60/1	3.0	2400 @ +20°F Evap	R-134a	No	Yes	Yes	Intela-Traul
R/ARI232LP	115/60/1	4.0	4360 @ +20°F Evap	R-134a	No	Yes	Yes	Intela-Traul
R/ARI332LP	115/60/1	5.0	5330 @ +20°F Evap	R-134a	No	Yes	Yes	Intela-Traul
R/ARI132H	115/60/1	2.0	2400 @ +20°F Evap	R-134a	No	Yes	Yes	Intela-Traul
R/ARI232H	115/60/1	3.0	4360 @ +20°F Evap	R-134a	No	Yes	Yes	Intela-Traul
R/ARI332H	115/60/1	4.0	5330 @ +20°F Evap	R-134a	No	Yes	Yes	Intela-Traul
R/AIF132L	115/60/1	7.5	2160 @ -20°F Evap	R-404A	No	Yes	Yes	Intela-Traul
R/AIF232L	115/60/1	11.0	5220 @ -20°F Evap	R-404A	No	Yes	Yes	Intela-Traul
R/AIF332L	208/115	12.0	7580 @ -20°F Evap	R-404A	No	Yes	Yes	Intela-Traul



TRAULSEN  
4401 BLUE MOUND RD.  
PHONE 1 (800) 825-8220  
Website: www.traulsen.com

FT. WORTH, TX 76106  
FAX-MKTG. 1 (817) 624-4302

# Remote Refrigeration Data

R/ACV132W	115/60/1	7.5	2160 @ -10°F Evap	R-404A	No	Yes	Yes	No
R/ACV232W	115/60/1	10.0	1870 @ -10°F Evap	R-404A	No	Yes	Yes	No
R/ADT132EW	115/60/1	6.5	F-1850 @ -20°F Evap R-1130 @ +20°F Evap	R-404A R-134a	No	Yes	Yes	Intela-Traul
R/ADT132W	115/60/1	6.5	F-1850 @ -20°F Evap R-1130 @ +20°F Evap	R-404A R-404A	No	Yes	Yes	Intela-Traul
R/ADT232W	115/60/1	8.0	F-2170 @ -20°F Evap R-1730 @ -20°F Evap	R-404A R-134a	No	Yes	Yes	Intela-Traul
R/ADT332W	115/60/1	9.0	F-2160 @ -20°F Evap R-4360 @ +20°F Evap	R-404A R-134a	No	Yes	Yes	Intela-Traul
R/ADT232N	115/60/1	8.0	F-2170 @ -20°F Evap R-1730 @ +20°F Evap	R-404A R-134a	No	Yes	Yes	Intela-Traul
R/ADT332N	115/60/1	9.0	F-2160 @ -20°F Evap R-4360 @ +20°F Evap	R-404A R-134a	No	Yes	Yes	Intela-Traul
R/ADT132K	115/60/1	6.5	F-1850 @ -20°F Evap R-1130 @ +20°F Evap	R-404A R-134a	No	Yes	Yes	Intela-Traul
R/ADT232D	115/60/1	6.5	F-1850 @ -20°F Evap R-1130 @ +20°F Evap	R-404A R-134a	No	Yes	Yes	Intela-Traul
RDH232W	208/115-1-60	10.0	2400 @ +20°F Evap	R-134a	No	Yes	Yes	Intela-Traul
RDH232WP	208/115-1-60	10.0	2400 @ +20°F Evap	R-134a	No	Yes	Yes	Intela-Traul
RRI264L	115/60/1	4.0	2 X 4360 @ +20°F Evap	R-134a	No	Yes	Yes	Intela-Traul
RRI364L	115/60/1	8.0	2 X 5330 @ +20°F Evap	R-134a	No	Yes	Yes	Intela-Traul
RRI264LP	115/60/1	4.0	2 X 4360 @ +20°F Evap	R-134a	No	Yes	Yes	Intela-Traul
RRI364LP	115/60/1	8.0	2 X 5330 @ +20°F Evap	R-134a	No	Yes	Yes	Intela-Traul
RIF264L	208/115/60/1*	12.0	10,440 @ -20°F Evap	R-404A	No	Yes	Yes	Intela-Traul
RIF364L	208/115/60/1*	14.0	15,160 @ -20°F Evap	R-404A	No	Yes	Yes	Intela-Traul
RHT232NSL	115/60/1	6.5	5330 @ +20°F Evap	R-134a	No	Yes	Yes	Intela-Traul
RHT232NHG	115/60/1	2.0	4360 @ +20°F Evap	R-134a	No	Yes	Yes	Intela-Traul
TE036HR <sup>11</sup>	115/60/1	3.2	2370 @ +20°F Evap	R-404A	Yes	Yes	Yes	Intela-Traul
TE048HR <sup>11</sup>	115/60/1	3.3	2370 @ +20°F Evap	R-404A	Yes	Yes	Yes	Intela-Traul
TE060HR <sup>11</sup>	115/60/1	3.5	2370 @ +20°F Evap	R-404A	Yes	Yes	Yes	Intela-Traul
TE065HR <sup>11</sup>	115/60/1	3.5	2370 @ +20°F Evap	R-404A	Yes	Yes	Yes	Intela-Traul
TE072HR <sup>11</sup>	115/60/1	3.6	2370 @ +20°F Evap	R-404A	Yes	Yes	Yes	Intela-Traul
TE084HR <sup>11</sup>	115/60/1	3.7	2370 @ +20°F Evap	R-404A	Yes	Yes	Yes	Intela-Traul
TE096HR <sup>11</sup>	115/60/1	3.9	4090 @ +20°F Evap	R-404A	Yes	Yes	Yes	Intela-Traul
TE110HR <sup>11</sup>	115/60/1	4.0	4090 @ +20°F Evap	R-404A	Yes	Yes	Yes	Intela-Traul
TU044HR	115/60/1	3.3	3080 @ +20°F Evap	R-404A	Yes	Yes	Yes	Intela-Traul
TU072HR	115/60/1	3.7	3080 @ +20°F Evap	R-404A	Yes	Yes	Yes	Intela-Traul
TU100HR	115/60/1	3.9	3080 @ +20°F Evap	R-404A	Yes	Yes	Yes	Intela-Traul
TS048HR	115/60/1	9.8	3300 @ +10°F Evap	R-404A	Yes	Yes	Yes	Intela-Traul
TS066HR	115/60/1	10.2	3870 @ +10°F Evap	R-404A	Yes	Yes	Yes	Intela-Traul
TS072HR	115/60/1	10.2	3870 @ +10°F Evap	R-404A	Yes	Yes	Yes	Intela-Traul
TS090HR	115/60/1	10.4	3870 @ +10°F Evap	R-404A	Yes	Yes	Yes	Intela-Traul

## NOTES:

- 1) Remote INTELA-TRAUL® equipped units do not require use of a temperature control.
- 2) Cord and plug are not supplied with remote units.
- 3) Listed BTU rating shown is the required BTU's delivered to the unit at the evaporator coil.
- 4) Compressor HP not supplied by Traulsen. Compressor size should be determined by a qualified refrigeration technician based on the delivered BTU rating at the unit and actual jobsite requirements.
- 5) To determine approximate remote model weights, please deduct 40 lbs. from the respective self-contained models net or gross weight.
- 6) Standard Traulsen five year compressor warranty does not apply to remote units.
- 7) Condensate Removal: except where noted above, all remote models require provisions to be made to allow for condensate removal. As supplied standard, these models include only a drain tube exiting the evaporator compartment on top of the cabinet from which condensate will drip. Optional condensate removal provisions include a drain line extended down the cabinet back (n/a for pass-thru or roll-thru models) or optional Top-Mounted Condensate Evaporator.  
Note: provision of the first option will add approximately 7/8" to the overall cabinet depth.
- 8) Traulsen does not recommend the use of casters with remote models (legs supplied standard on G-Series remote units).
- 9) Refrigeration connections provided are 1/4" O.D. for the liquid line and either 1/2" or 3/4" O.D. for the suction line, no other connections are required.
- 10) The solenoid valve provided is wired at the factory directly to the control, and so no electrical connections are required between the unit and remote compressor.
- 11) Traulsen's equipment stands are solely intended for use with cooking equipment.

Continued product development may necessitate specification changes without notice.

Part No. TR35837 (REV. 06-12-15)

TRAULSEN  
4401 BLUE MOUND RD.  
PHONE 1 (800) 825-8220  
Website: www.traulsen.com

FT. WORTH, TX 76106  
FAX-MKTG. 1 (817) 624-4302

