



TRUE FOOD SERVICE EQUIPMENT, INC.

2001 East Terra Lane • O'Fallon, Missouri 63366
 (636)240-2400 • Fax (636)272-2408 • (800)325-6152 • Intl Fax# (001)636-272-7546
 Parts Dept. (800)424-TRUE • Parts Dept. Fax# (636)272-9471 • www.truemfg.com

Project Name: _____

Location: _____

Item #: _____ Qty: _____

Model #: _____

A/A #

S/S #

Model:
GDM-9-LD

Glass Door Merchandiser:

Slide Door Counter-Top Refrigerator with LED Lighting



Shown with optional black exterior.



Scan code for video

GDM-9-LD

- ▶ The world's #1 manufacturer of glass door merchandisers.
- ▶ True's commitment to using the highest quality materials and oversized refrigeration systems provides the user with colder product temperatures, and lower utility costs in an attractive merchandiser that brilliantly displays packaged food and beverages.
- ▶ Designed for convenient access, fast service, and attractive display.
- ▶ Oversized, factory balanced, refrigeration system holds 33°F to 38°F (.5°C to 3.3°C).
- ▶ Exterior - non-peel or chip white laminated vinyl; durable and permanent.
- ▶ Interior - attractive, NSF approved, white aluminum interior liner with stainless steel floor.
- ▶ Self closing doors. Counter-balanced weight system for smooth, even, positive closing.
- ▶ "Low-E", double pane thermal insulated glass door assemblies with mitered plastic channel frames. The latest in energy efficient technology.
- ▶ LED interior lighting provides more even lighting throughout the cabinet. Safety shielded.
- ▶ Entire cabinet structure is foamed-in-place using Ecomate. A high density, polyurethane insulation that has zero ozone depletion potential (ODP) and zero global warming potential (GWP).

ROUGH-IN DATA

Specifications subject to change without notice.
 Chart dimensions rounded up to the nearest 1/8" (millimeters rounded up to next whole number).

| Model | Doors | Shelves | Cabinet Dimensions (inches) (mm) | | | HP | Voltage | Amps | NEMA Config. | Cord Length (total ft.) (total m) | Crated Weight (lbs.) (kg) |
|----------|-------|---------|----------------------------------|--------|--------|-----|--------------|------|--------------|-----------------------------------|---------------------------|
| | | | L | D† | H | | | | | | |
| GDM-9-LD | 2 | 3 | 36 1/8 | 22 3/8 | 39 1/2 | 1/5 | 115/60/1 | 4.1 | 5-15P | 9 | 265 |
| | | | 918 | 569 | 1004 | 1/4 | 230-240/50/1 | 3.0 | ▲ | 2.74 | 121 |

† Depth does not include 3/4" (20 mm) for door handles.

▲ Plug type varies by country.



APPROVALS:

AVAILABLE AT:

Model:
GDM-9-LD

Glass Door Merchandiser:
Slide Door Counter-Top Refrigerator with LED Lighting



STANDARD FEATURES

DESIGN

- True's commitment to using the highest quality materials and oversized refrigeration systems provides the user with colder product temperatures, and lower utility costs in an attractive merchandiser that brilliantly displays packaged food and beverages.

REFRIGERATION SYSTEM

- Factory engineered, self-contained, capillary tube system using environmentally friendly (CFC free) 134A refrigerant.
- Extra large evaporator coil balanced with higher horsepower compressor and large condenser; maintains cabinet temperatures of 33°F to 38°F (.5°C to 3.3°C).
- Sealed, cast iron, self-lubricating evaporator fan motor(s) and larger fan blade gives True merchandisers a more efficient low velocity, high volume airflow design. This unique design ensures faster temperature pull down of warm product, colder holding temperatures and faster recovery in high use situations.

CABINET CONSTRUCTION

- Exterior - non-peel or chip white laminated vinyl; durable and permanent.
- Interior - attractive, NSF approved, white aluminum liner with stainless steel floor.

- Insulation - entire cabinet structure is foamed-in-place using Ecomate. A high density, polyurethane insulation that has zero ozone depletion potential (ODP) and zero global warming potential (GWP).
- Cabinet fitted with leg levelers.
- Illuminated exterior sign panel. Variety of sign options available.

DOORS

- "Low-E", double pane thermal insulated glass door assemblies with mitered plastic channel frame. The latest in energy efficient technology.
- Each door fitted with 12" (305 mm) long handles.
- Self closing doors. Counter-balanced weight system for smooth, even, positive closing.

SHELVING

- Three (3) adjustable, heavy duty PVC coated wire shelves: two (2) 31 3/4" x 15" (807 mm x 381 mm) and one (1) 31 3/4" x 8 7/16" (807 mm x 215 mm). Four (4) chrome plated shelf clips included per shelf.
- Shelf support pilasters made of same material as cabinet interior; shelves are adjustable on 1/2" (13 mm) increments.

LIGHTING

- LED interior lighting provides more even lighting throughout the cabinet. Safety shielded.

MODEL FEATURES

- Evaporator is epoxy coated to eliminate the potential of corrosion.
- See our website www.truemfg.com for latest color and sign offerings.
- NSF-7 compliant for open food product.

ELECTRICAL

- Unit completely pre-wired at factory and ready for final connection to a 115/60/1 phase, 15 amp dedicated outlet. Cord and plug set included.



115/60/1
NEMA-5-15R

OPTIONAL FEATURES/ACCESSORIES

Upcharge and lead times may apply.

- 230 - 240V / 50 Hz.
- 4" (102 mm) legs.
- Black exterior.
- Walnut exterior.
- Stainless steel exterior model available.
- Red wine thermostat.
- White wine thermostat.
- Chocolate thermostat.
- Additional shelving.
- 1 1/4" (32 mm) pricing strips.

PLAN VIEW

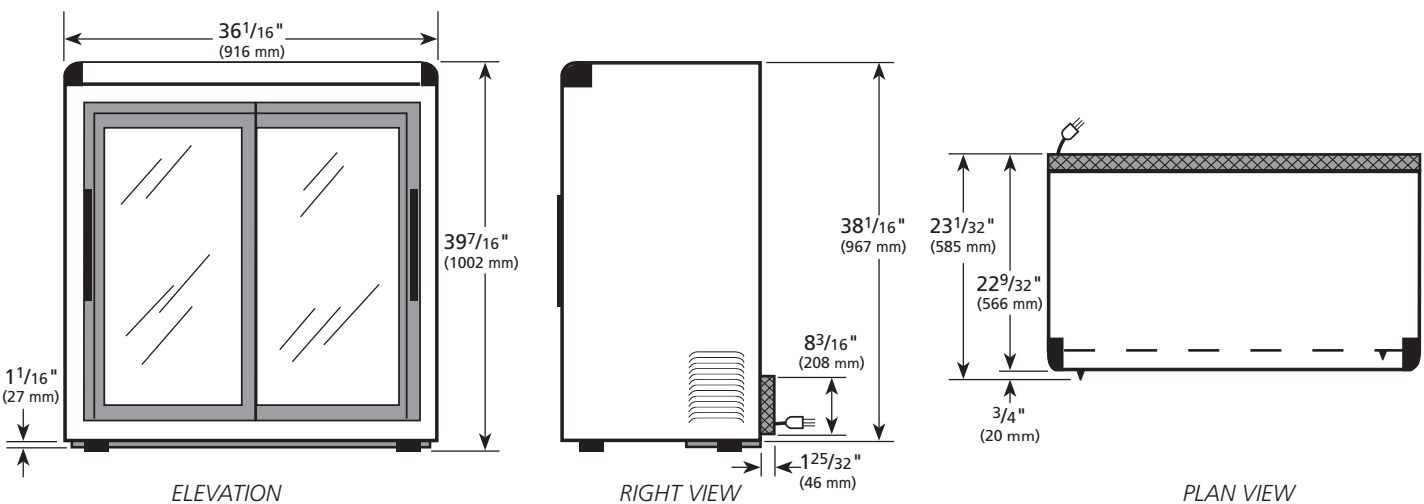

WARRANTY*
 Three year warranty on all parts and labor and an additional 2 year warranty on compressor. (U.S.A. only)

METRIC DIMENSIONS ROUNDED UP TO THE NEAREST WHOLE MILLIMETER

SPECIFICATIONS SUBJECT TO CHANGE WITHOUT NOTICE



| Model | Elevation | Right | Plan | 3D | Back |
|----------|-----------|----------|----------|----------|------|
| GDM-9-LD | TFAY070E | TFAY070S | TFAY070P | TFAY0703 | |

*RESIDENTIAL APPLICATIONS: TRUE assumes no liability for parts or labor coverage for component failure or other damages resulting from installation in non-commercial or residential applications.

TRUE FOOD SERVICE EQUIPMENT