



PROJECT NAME		LOCATION		AIA #
ITEM #	QTY	MODEL #		SIS #

# SPEC SERIES®

ROLL-THRU SOLID SWING DOOR HEATED CABINET

models	STR1HRT89-1S-1S	STA1HRT89-1S-1S	STG1HRT89-1S-1S
--------	-----------------	-----------------	-----------------



STR1HRT89-1S-1S	
<b>Exterior</b>	Stainless steel door, front & sides.
<b>Interior</b>	Stainless steel side walls, back, floor, door liner, & ceiling.

STA1HRT89-1S-1S	
<b>Exterior</b>	Stainless steel door, front & sides.
<b>Interior</b>	Aluminum side walls & back. Stainless steel floor & ceiling.

STG1HRT89-1S-1S	
<b>Exterior</b>	Stainless steel door, with matching aluminum sides.
<b>Interior</b>	Aluminum side walls & back. Stainless steel floor & ceiling.

## plan view

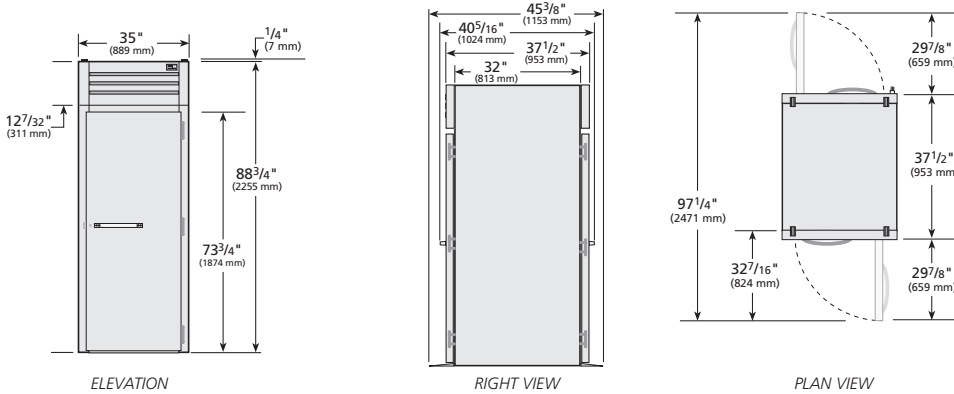

SPECIFICATIONS		
Dimensions	in.	mm.
Length	35	889
Depth	37 1/2	953
Height	89	2261
Electrical	U.S.	International
Watts	2000	
Voltage	115/208-230/60	
NEMA	14-20P	
Cord Length	9 ft.	2.74 M.
115/208-230/1 NEMA-14-20R † Depth does not include 4 1/8" (105 mm) for ramp each side. * Height does not include 1" (26 mm) for system mechanical components. Requires 115/208-240/60 Hz, single phase, 3 pole, 4 wire circuit.		

Specifications subject to change without notice.  
 Chart dimensions are rounded up to the nearest 1/8" (millimeters rounded up to the next whole number).

	<b>APPROVALS</b>	<b>AVAILABLE AT</b>
6/13	Printed in U.S.A.	



PROJECT NAME	LOCATION	AIA #
ITEM #	QTY	MODEL #
		SIS #

# SPEC SERIES®

ROLL-THRU SOLID SWING DOOR HEATED CABINET

models	STR1HRT89-1S-1S	STA1HRT89-1S-1S	STG1HRT89-1S-1S
--------	-----------------	-----------------	-----------------



## standard features

### HEATER SYSTEM

- Cabinet designed to provide holding temperatures of 140°F to 180°F (60°C to 82.2°C). Heating system controlled by exterior on/off switch and electronic temperature control.
- Two (2) stainless steel (for corrosion resistance), finned tube heating elements (1000 watts each) for uniform generation of electric heat. Cabinet comes with a total of 2000 watts.
- Equipped with low-velocity fans to assure even temperature distribution throughout the cabinet. Fans are controlled by exterior on/off switch.
- Manually controlled vent located on top of the cabinet for positive humidity control.

### CABINET CONSTRUCTION

- Stainless steel breaker caps.
- Insulation - entire cabinet structure and solid door are foamed-in-place using Ecomate. A high density, polyurethane insulation that has zero ozone depletion potential (ODP) and zero global warming potential (GWP).
- One (1) heavy gauge stainless steel ramp.

- Designed to accept roll-in racks (inboard castors) with maximum dimensions of 27"L x 29"D x 72"H (686 mm x 737 mm x 1829 mm) (supplied by others).

### DOORS

- Lifetime guaranteed bolt style door locks standard.
- Lifetime guaranteed heavy duty all metal working door handles.
- Positive seal self-closing doors with 120° stay open feature. Lifetime guaranteed external cam lift door hinges, Three (3) per door section.
- Magnetic door gasket of one piece construction, removable without tools for ease of cleaning.

### LIGHTING

- Incandescent interior lighting; lights activated by exterior on/off switch, safety shielded.

### MODEL FEATURES

- Exterior, color coded, temperature display; accurate direct reading of internal cabinet temperature.
- Designed to hold warm baked or cooked food. Cabinet is not designed to heat ambient or cold product.
- Interior bumpers protect cabinet walls from abuse caused by roll-in carts.

- 12" x 20" (305 mm x 508 mm) pan for water included, if additional humidity is required.
- NSF-4 compliant for open food product.

### ELECTRICAL

- True requires that a sole use circuit be dedicated for the unit.
- Unit completely pre-wired at factory and ready for final connection to a 115/208-240/60 Hz. single phase, 20 amp dedicated outlet. Cord and plug set included.

### OPTIONAL FEATURES/ ACCESSORIES

*(upcharge & lead times may apply)*

- Field reversible hinge
- Stainless back. (STR, STA, STG)
- Correctional facilities options.

**WARRANTY**  
 Three year warranty on all parts and labor and an additional 2 year warranty on compressor. (U.S.A. only)

METRIC DIMENSIONS ROUNDED UP TO THE NEAREST WHOLE MILLIMETER  
 SPECIFICATIONS SUBJECT TO CHANGE WITHOUT NOTICE



Model	Elevation	Right	Plan	3D	Back
ST( )1HRT89-1S-1S					