



**TRUE FOOD SERVICE
EQUIPMENT, INC.**

2001 East Terra Lane • O'Fallon, Missouri 63366
(636)240-2400 • Fax (636)272-2408 • (800)325-6152 • Intl Fax# (001)636-272-7546
Parts Dept. (800)424-TRUE • Parts Dept. Fax# (636)272-9471 • www.truemfg.com

Project Name: _____

Location: _____

Item #: _____ Qty: _____

Model #: _____

A/A #

SIS #

Model:
TCGD-36

Display Case:
Curved Glass Dry Bakery Case



TCGD-36

- ▶ True's non-refrigerated "dry" display case combines efficient, high volume merchandising with an elegant curved glass front for sophisticated presentation of breads, desserts and pastries.
- ▶ Cabinet is NSF-2 certified to hold open food product.
- ▶ Single pane curved glass front and side panels provide extra large viewing area to maximize bakery product presentation. Front glass tilts forward for easy cleaning.
- ▶ Three (3) adjustable PVC coated shelves.
- ▶ Special "brown bulb" lighting provides balanced color spectrum that enhances the appearance of bakery products.
- ▶ Exterior front and sides standard with white laminate panels, five additional color options available at no charge. Stainless steel top.
- ▶ White aluminum interior sides and top. High impact plastic floor with coved corners.

ROUGH-IN DATA

Specifications subject to change without notice.
Chart dimensions rounded up to the nearest 1/8" (millimeters rounded up to next whole number).

Model	Doors	Shelves	Cabinet Dimensions (inches) (mm)			Voltage	Amps	Crated Weight (lbs.) (kg)
			L	D†	H			
TCGD-36	2	3	36 7/8	38 1/8	47 7/8	115/60/1 230-240/50/1	0.6 0.2	405
			937	969	1217			184

† Depth does not include 1 3/8" (35 mm) for rear door handles.
note: Standard Dry Bakery Cases require hard wiring.
Optional, factory installed, 12" cord set available (exterior scale receptacle will not be included with this option; upcharge applies).



APPROVALS:

AVAILABLE AT:

Model:
TCGD-36

Display Case:
Curved Glass Dry Bakery Case



STANDARD FEATURES

DESIGN

- True's "dry" display case combines efficient, high volume merchandising with an elegant curved glass front for sophisticated presentation of breads, desserts and pastries.
- Designed to provide an attractive companion to our forced-air refrigerated display case.

CABINET CONSTRUCTION

- Exterior - white laminate front and side panels. Color options available at no charge (upcharge for stainless steel):



Walnut | Teak | Oak | Beige | Black | White

- All laminate (and stainless option) ships separately from unit and is field installed. Stainless steel top. Black front and rear grills and trim. Custom template kit available at no charge for field installation of laminate.
- Interior - NSF approved white aluminum sides and top; high impact plastic floor with coved corners.
- Welded, heavy duty steel frame rail, black powder coated for corrosion protection.
- Frame rail fitted with leg levelers.

CURVED FRONT DISPLAY GLASS

- Single pane curved glass front and side panels provide extra large viewing area to maximize bakery product presentation. Glass is tempered for safety.
- Front glass tilts forward for easy cleaning.

REAR DOORS

- "Low-E"; double pane thermal glass door assemblies with extruded aluminum frames. The latest in energy efficient technology.

- Each door fitted with 12" (305 mm) long molded plastic handle.
- Self closing doors. Positive seal, torsion type closure system.
- Magnetic door gaskets of one piece construction, removable without tools for ease of cleaning.

SHELVING

- Three (3) adjustable, heavy duty PVC coated wire shelves 30³/₈"L x 22⁵/₃₂"D (772 mm x 563 mm). Shelving system is cantilevered and angle can be adjusted to maximize presentation.
- Each shelf supports a maximum weight of 150 lbs. (69 kg).

PAN CAPACITY

- Cabinet holds four (4) 18"L x 26"D (458 mm x 661 mm) display pans (1 per level) and four (4) 9"L x 26"D (229 mm x 661 mm) display pans (1 per level). Pans supplied by others.

LIGHTING

- Cabinet equipped with four (4) light sources for maximum product display; three (3) shelf mounted and one (1) cabinet mounted. Special "brown bulb" lighting provides balanced color spectrum that enhances the appearance of bakery products.
- Safety shielded lighting tubes assure longer, brighter, shadow-free product illumination.

MODEL FEATURES

- Recessed exterior light switch.
- NSF-2 compliant for open food product.

ELECTRICAL

- Unit comes with 4 feed wires (including ground) to be hardwired at installation site to a 115/60/1 phase, 15 amp dedicated outlet.

OPTIONAL FEATURES/ACCESSORIES

Upcharge and lead times may apply.

- 230 - 240V / 50 Hz.
- 6" (153 mm) standard legs.
- 6" (153 mm) seismic/flanged legs.
- 2¹/₂" (64 mm) diameter castors [NOTE: castors can not be installed on units that are hardwired, optional 12" (305 mm) power cord must be factory installed].
- 12" (305 mm) cord set (factory installed).
- Custom exterior laminates, contact factory for details. See our website: www.truemfg.com for the latest color offerings.
- Stainless steel exterior (field installed).
- Mirrored interior ends with laminate exterior.
- Additional lighted shelves.
- Additional non-lighted shelves.

PLAN VIEW

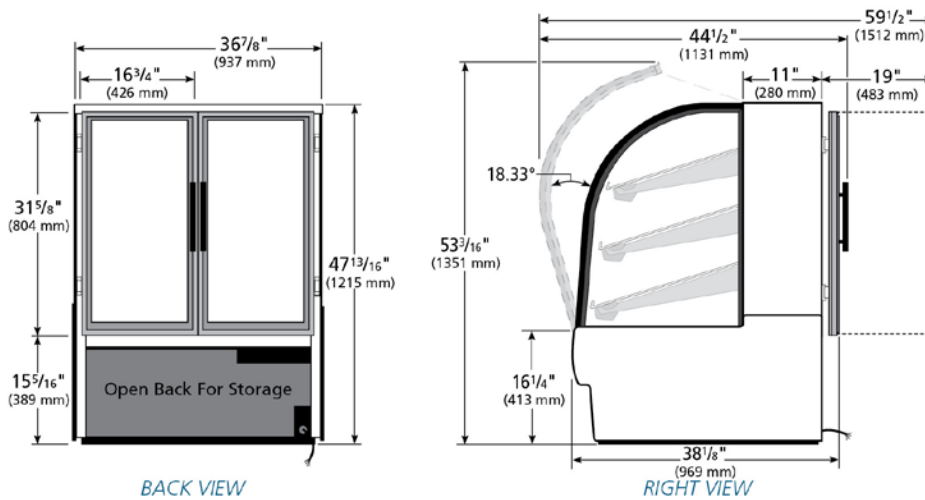

WARRANTY
One year warranty on all parts and labor. (U.S.A. only)

METRIC DIMENSIONS ROUNDED UP TO THE NEAREST WHOLE MILLIMETER
SPECIFICATIONS SUBJECT TO CHANGE WITHOUT NOTICE

	Model	Elevation	Right	Plan	3D	Back
	TCGD-36	TFD076E	TFD076S	TFD081P	TFD0813	TFD081B

TRUE FOOD SERVICE EQUIPMENT