



**TRUE FOOD SERVICE  
EQUIPMENT, INC.**

2001 East Terra Lane • O'Fallon, Missouri 63366  
 (636)240-2400 • Fax (636)272-2408 • (800)325-6152 • Intl Fax# (001)636-272-7546  
 Parts Dept. (800)424-TRUE • Parts Dept. Fax# (636)272-9471 • www.truemfg.com

Project Name: \_\_\_\_\_

Location: \_\_\_\_\_

Item #: \_\_\_\_\_ Qty: \_\_\_\_\_

Model #: \_\_\_\_\_

A/A #

SIS #

Model:  
**TFM-29AL**

**Horizontal Freezer:**  
*Glass Angled Lid*



**TFM-29AL**

- ▶ True's horizontal freezers are uniquely designed to promote high-profit frozen novelties in high impulse retail traffic areas. Ideal for bolstering incremental sales of frozen merchandise and seasonal specialties.
- ▶ Cold wall, environmentally friendly (134A) refrigeration system. Maintains -10°F (-23.33°C), ideal for both ice cream and frozen food.
- ▶ Exterior - non-peel or chip white laminated vinyl, durable and permanent; with gray mitered plastic top and lid frames.
- ▶ Interior - NSF approved, white aluminum with 300 series stainless steel floor.
- ▶ Tempered, hard coated, "Low-E" glass slide lids. Reduces solar heat gain, enhances energy efficiency and minimizes condensation.
- ▶ Locks standard, provide security, prevents theft.
- ▶ Convenient defrost drain.
- ▶ 2½" (64 mm) diameter stem castors.
- ▶ Entire cabinet structure is foamed-in-place using Ecomate. A high density, polyurethane insulation that has zero ozone depletion potential (ODP) and zero global warming potential (GWP).

**ROUGH-IN DATA**

Specifications subject to change without notice.  
 Chart dimensions rounded up to the nearest 1/8" (millimeters rounded up to next whole number).

Model	Lids	Cabinet Dimensions (inches) (mm)			HP	Voltage	Amps	NEMA Config.	Cord Length (total ft.) (total m)	Crated Weight (lbs.) (kg)
		L	D	H*						
TFM-29AL	2	29 7/8 759	26 3/8 670	34 864	1/5	115/60/1	2.6	5-15P	9 2.74	150 69

\* Height does not include 3/4" (83 mm) for castors and 5/8" (16 mm) for lid handle.



APPROVALS:

AVAILABLE AT:

Model:  
**TFM-29AL**

## Horizontal Freezer: Glass Angled Lid



### STANDARD FEATURES

#### DESIGN

- True's horizontal freezers are uniquely designed to promote high-profit frozen novelties in high impulse retail traffic areas. Ideal for bolstering incremental sales increases of frozen merchandise and seasonal specialties.

#### REFRIGERATION SYSTEM

- Factory engineered, self-contained, capillary tube system using environmentally friendly (CFC free) 134A refrigerant.
- Cold wall refrigeration system. Maintains -10°F (23.3°C) cabinet temperature, ideal for both ice cream and frozen food.
- Condensing unit is accessed from behind grill on right side; slides out for easy maintenance.
- Manual defrost system; convenient drain located on front of cabinet.

#### CABINET CONSTRUCTION

- Exterior- non-peel or chip white laminated vinyl, durable and permanent; with gray mitered plastic top and lid frames.
- Interior- attractive, NSF approved, white aluminum liner; non-rust, peel or chip. 300 series stainless steel floor.

- Insulation - entire cabinet structure is foamed-in-place using Ecomate. A high density, polyurethane insulation that has zero ozone depletion potential (ODP) and zero global warming potential (GWP).
- 2 1/2" (64mm) diameter stem castors.

#### LIDS

- Angled tempered, hard coated "low-E", single pane glass slide lid assemblies. The latest in energy efficient technology; reduces solar heat gain and minimizes condensation.
- Designed for convenient access, fast service and attractive display.
- Lid lock standard.

#### MODEL FEATURES

- Self-contained, portable system. No plumbing required.
- Low profile design permits easier placement, saves aisle space.
- Interior mounted thermometer.
- NSF-7 compliant for open food product.

#### ELECTRICAL

- Unit completely pre-wired at factory and ready for final connection to a 115/60/1 phase, 15 amp dedicated outlet. Cord and plug set included.



115/60/1  
NEMA-5-15R

#### OPTIONAL FEATURES/ACCESSORIES

Upcharge and lead times may apply.

- Black vinyl exterior.
- Heavy duty novelty baskets (accommodates 2).
- Dividers for novelty baskets.

### PLAN VIEW

CUBIC FEET 6.3/178

\*Based on ANSI/AHAM HRF-1-2004

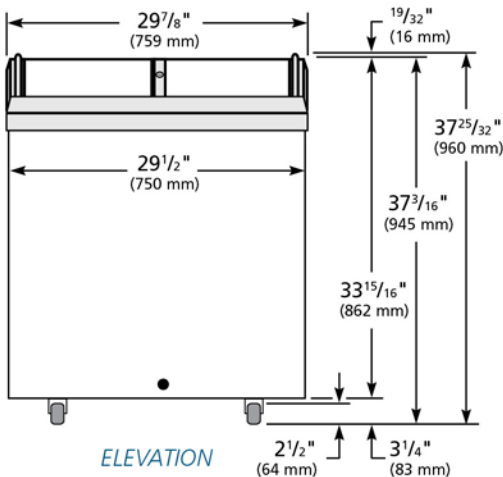

ELEVATION

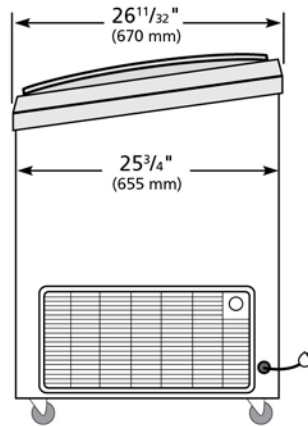

RIGHT VIEW

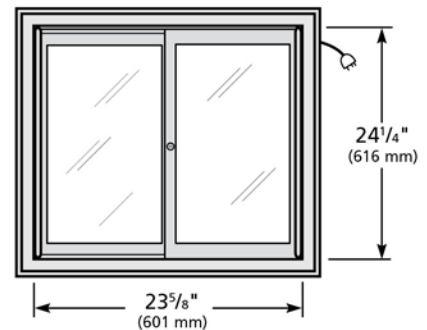

PLAN VIEW

#### WARRANTY

One year warranty on all parts and labor and an additional 4 year warranty on compressor. (U.S.A. only)

METRIC DIMENSIONS ROUNDED UP TO THE NEAREST WHOLE MILLIMETER

SPECIFICATIONS SUBJECT TO CHANGE WITHOUT NOTICE



Model	Elevation	Right	Plan	3D	Back
TFM-29AL					

### TRUE FOOD SERVICE EQUIPMENT

2001 East Terra Lane • O'Fallon, Missouri 63366 • (636)240-2400 • Fax (636)272-2408 • (800)325-6152 • Intl. Fax# (001)636-272-7546 • www.truefmfg.com