



TRUE FOOD SERVICE EQUIPMENT, INC.

2001 East Terra Lane • P.O. Box 970 • O'Fallon, Missouri 63366
 (636)240-2400 • Fax (636)272-2408 • (800)325-6152 • Intl Fax# (001)636-272-7546
 Parts Dept. (800)424-TRUE • Parts Dept. Fax# (636)272-9471 • www.truefmfg.com

Project Name: _____

Location: _____

Item #: _____ Qty: _____

Model #: _____

A/A #

SIS #

Model:
TWT-48-ADA

Worktop:
ADA Compliant Solid Door Refrigerator



TWT-48-ADA

- ▶ True's worktop units are designed with enduring quality that protects your long term investment.
- ▶ Designed using the highest quality materials and components to provide the user with colder product temperatures, lower utility costs, exceptional food safety and the best value in today's food service marketplace.
- ▶ 3" (77 mm) diameter stem castors standard. 34" (864 mm) work surface height. Complies with the Americans with Disabilities Act (ADA) requirements.
- ▶ Oversized, environmentally friendly (R404A) forced-air refrigeration system holds -10°F (-23.3°C). Ideally suited for both frozen foods and ice cream.
- ▶ All stainless steel front, top and ends. Matching aluminum finished back. Top and backsplash are one piece formed construction. Bacteria and food particles cannot be trapped underneath as with other two-piece worktop units.
- ▶ Front breathing.
- ▶ Heavy duty PVC coated wire shelves.
- ▶ Foamed-in-place, high density polyurethane insulation (CFC free).

ROUGH-IN DATA

Specifications subject to change without notice.
 Chart dimensions rounded up to the nearest 1/8" (millimeters rounded up to next whole number).

Model	Doors	Capacity (Cu. Ft.) (liters)	Shelves	Cabinet Dimensions (inches) (mm)			Counter Height	HP	Voltage	Amps	NEMA Config.	Cord Length (total ft.) (total m)	Crated Weight (lbs.) (kg)
				L	D†	H*							
TWT-48-ADA	2	12 340	4	48 3/8 1229	30 1/8 766	33 3/8 848	34	1/2 1/2	115/60/1 230-240/50/1	5 4.2	5-15P ▲	7 2.13	290 132

† Depth does not include 1" (26 mm) for rear bumpers.
 * Height does not include 4" (102 mm) for castors.

▲ Plug type varies by country.

	APPROVALS: 	AVAILABLE AT:
Printed in U.S.A.		

Model:
TWT-48-ADA

Worktop:
ADA Compliant Solid Door Refrigerator



STANDARD FEATURES

DESIGN

- True's commitment to using the highest quality materials and oversized refrigeration systems provides the user with colder product temperatures, lower utility costs, exceptional food safety and the best value in today's food service marketplace.

REFRIGERATION SYSTEM

- Factory engineered, self-contained, capillary tube system using environmentally friendly (CFC free) 134A refrigerant.
- Oversized, factory balanced refrigeration system with guided airflow to provide uniform product temperatures.
- Extra large evaporator coil balanced with higher horsepower compressor and large condenser; maintains cabinet temperatures of 33°F to 38°F (5.5°C to 3.3°C) for the best in food preservation.
- Sealed, cast iron, self-lubricating evaporator fan motor(s) and larger fan blades give True worktop units a more efficient, low velocity, high volume airflow design. This unique design ensures faster temperature recovery and shorter run times in the busiest of foodservice environments.
- Condensing unit access in back of cabinet, slides out for easy maintenance.

CABINET CONSTRUCTION

- Exterior - stainless steel front, top and ends. Matching aluminum finished back. Top and backplash are one piece formed construction. Bacteria and food particles cannot be trapped underneath as with other two-piece worktop units.
- Interior - attractive, NSF approved, white aluminum liner. 300 series stainless steel floor with coved corners.
- Insulation - entire cabinet structure and solid door(s) are foamed-in-place using high density, CFC free, polyurethane insulation.
- 3" (77 mm) diameter stem castors. 34" (864 mm) work surface height. Compliant with American Disabilities Act (ADA) requirements.

DOORS

- Stainless steel exterior with white aluminum liner to match cabinet interior.

- Each door fitted with 12" (305 mm) long recessed handle that is foamed-in-place with a sheet metal interlock to ensure permanent attachment.
- Positive seal self-closing doors with 90° stay open feature. Doors swing within cabinet dimensions.
- Magnetic door gaskets of one piece construction, removable without tools for ease of cleaning.

SHELVING

- Four (4) adjustable, heavy duty PVC coated wire shelves 21⁵/₁₆" L x 16"D (548 mm x 407 mm). Four (4) chrome plated shelf clips included per shelf.
- Shelf support pilasters made of same material as cabinet interior; shelves are adjustable on 1/2" (13 mm) increments.

COUNTERTOP PAN CAPACITY

- Countertop pan opening designed to fit varying size pan configurations with available pan divider bars. Varying size pans supplied by others.

MODEL FEATURES

- Evaporator is epoxy coated to eliminate the potential of corrosion.
- Comes standard with 16 (1/2 size) 6⁷/₈" L x 6¹/₄" W x 4"D (175 mm x 159 mm x 102 mm) clear polycarbonate, NSF approved, food pans in countertop prep area. Also accommodates 6" (153 mm) and 8" (204 mm) deep food pans (supplied by others).
- NSF-7 compliant for open food product.

ELECTRICAL

- Unit completely pre-wired at factory and ready for final connection to a 115/60/1 phase, 15 amp dedicated outlet. Cord and plug set included.



OPTIONAL FEATURES/ACCESSORIES

Upcharge and lead times may apply.

- 230 - 240V / 50 Hz.
- 6" (153 mm) standard legs.
- 6" (153 mm) seismic/flanged legs.
- 5" (127 mm) diameter stem casters.
- Barrel locks (factory installed). Requires one per door.

- Single overshelf.
- Double overshelf.
- 28¹/₄" (718 mm) deep, 1/2" (13 mm) thick, white polyethylene cutting board. Requires "L" brackets.
- 28¹/₄" (718 mm) deep, 1/2" (13 mm) thick, composite cutting board. Requires "L" brackets.
- Heavy duty 16 gauge tops.
- Exterior rectangular digital temperature display (factory installed).
- Remote cabinets (condensing unit supplied by others; system comes standard with 404A expansion valve and requires R404A refrigerant). Consult factory technical service department for BTU information. All remote units must be hard wired during installation.

PLAN VIEW

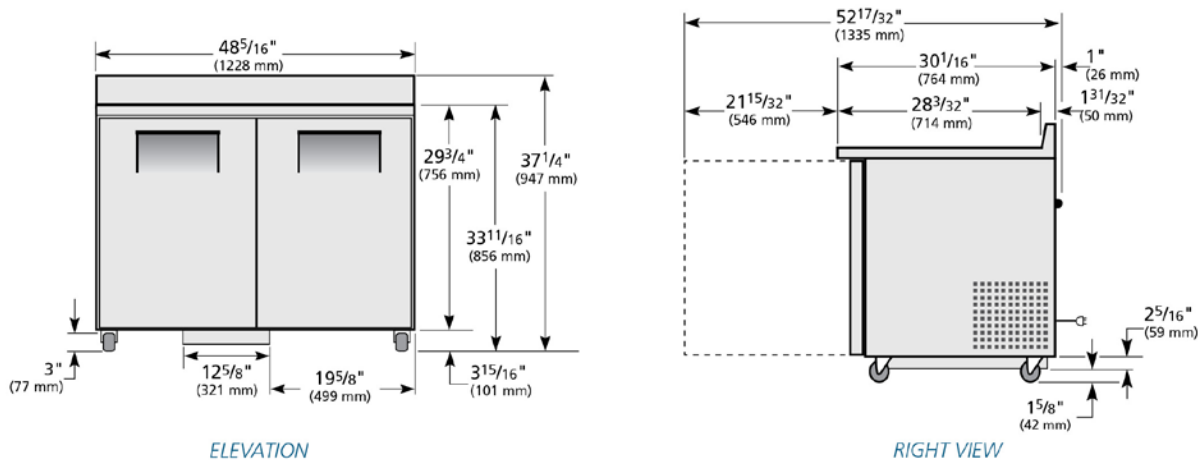

WARRANTY
One year warranty on all parts and labor and an additional 4 year warranty on compressor. (U.S.A. only)

METRIC DIMENSIONS ROUNDED UP TO THE NEAREST WHOLE MILLIMETER
SPECIFICATIONS SUBJECT TO CHANGE WITHOUT NOTICE

	Model	Elevation	Right	Plan	3D	Back
	TWT-48-ADA	TFPY38E	TFPY38S	TFPY02P	TFPY383	

TRUE FOOD SERVICE EQUIPMENT