

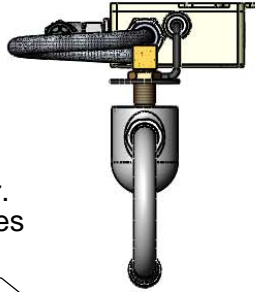

ADA Compliant

016739-40
Swivel Gooseneck w/
2.2 GPM [8.3 LPM]
Vandal Resistant Aerator.
Rigid Conversion Requires
01742145 Lock Washer
(Included)



30" [762mm] Long
Flexible Stainless
Steel Hose Between
Shank & Control
Module

9 9/16"
[243mm]

Removable
Strainer

Mechanical Mixing
Valve w/ Integral
Check Valves

(2) 18" [457mm]
Flexible Stainless
Steel Supply Hoses.
1/2" NPSM Female
x 3/8" Compression
Female

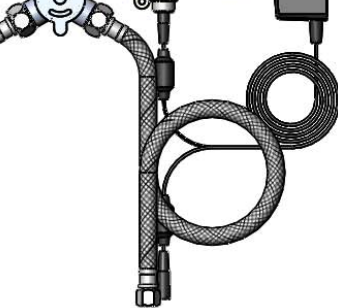
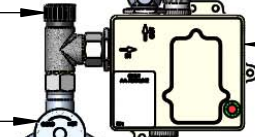
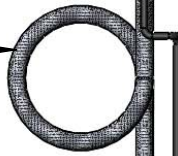
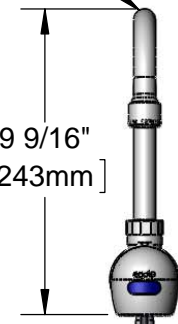

24" [610mm]
Sensor Cable

3 5/8" x 4 3/16" x 2" Deep
[92mm x 106mm x 51mm]
Control Module Box (White)
w/ Water Resistant Connections.
AC or DC Operated w/
(4) AA Batteries

100-240 VAC Adapter
w/ 144" [3658mm]
Long Double Power Cord

Notes:
Rough-In Requirement
Ø 1 1/8" [29mm] Mounting Hole

This Space for Architect/Engineer Approval

Job Name _____ Date _____

Model Specified _____ Quantity _____

Customer/Wholesaler _____

Contractor _____

Architect/Engineer _____

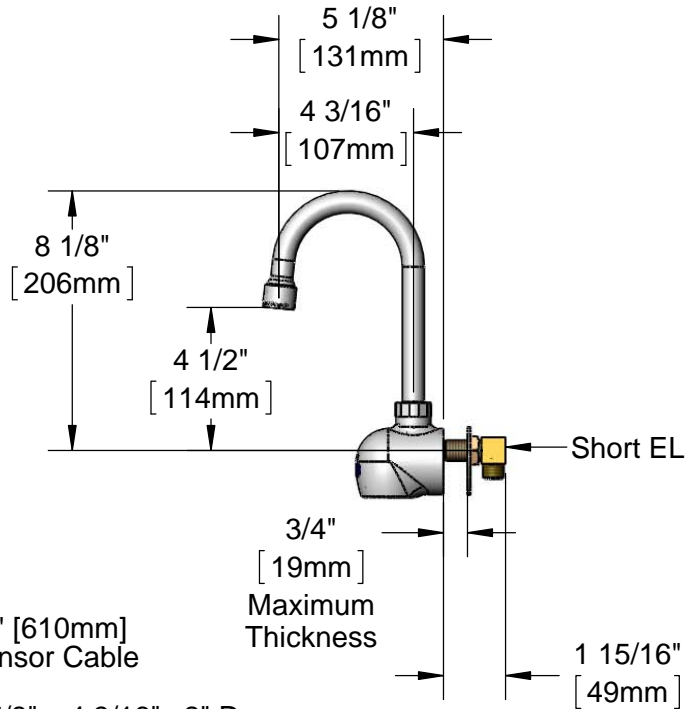

Model Number 5EF-1D-WGAT	Date 03/18/13	Scale 1:6	Drawn DHL	Checked DMH	Approved JHB
-----------------------------	------------------	--------------	--------------	----------------	-----------------

Product Specifications:
Electronic Faucet: Wall Mount Swivel Gooseneck w/ 2.2 GPM VR Aerator, AC-DC Control Module, Temperature Control Mixing Valve w/ Integral Check Valves & 18" Long Flexible Supply Stop Hoses



equip Foodservice Accessories
2 Saddleback Cove, P.O. Box 1088
Travelers Rest, South Carolina 29690
Phone: 800.891.4808 Fax: 800.868.0084

ITEM NO.	SALES NO.	DESCRIPTION
1	B-0199-06	VR 2.2 GPM Aerator, 55/64"-27 UN Female w/ Key
2	016739-40	Swivel Gooseneck w/ 2.2 GPM Vandal Resistant Aerator (5EF-1D-WGAT)
3	017421-45	Serrated Lock Washer
4	5EF-0003	24" Sensor Cable
5	015345-20	3/8-18 Low Profile Elbow
6	016325-45	Inlet Hose, Faucet, 1/2" NPSM-F x 3/8" NPSM-F
7	5EF-0001	equip Sensor Faucet - Control Module
8	5EF-0002	equip AC Transformer, 100-240 VAC
9	5EF-0005	Supply Hose, 3/8" Compression x 1/2" NPSM
10	5EF-0006	Mechanical Mixing Valve
11	5EF-FILTER	Replacement Filter
12	015425-45	Vandal Resistant Key

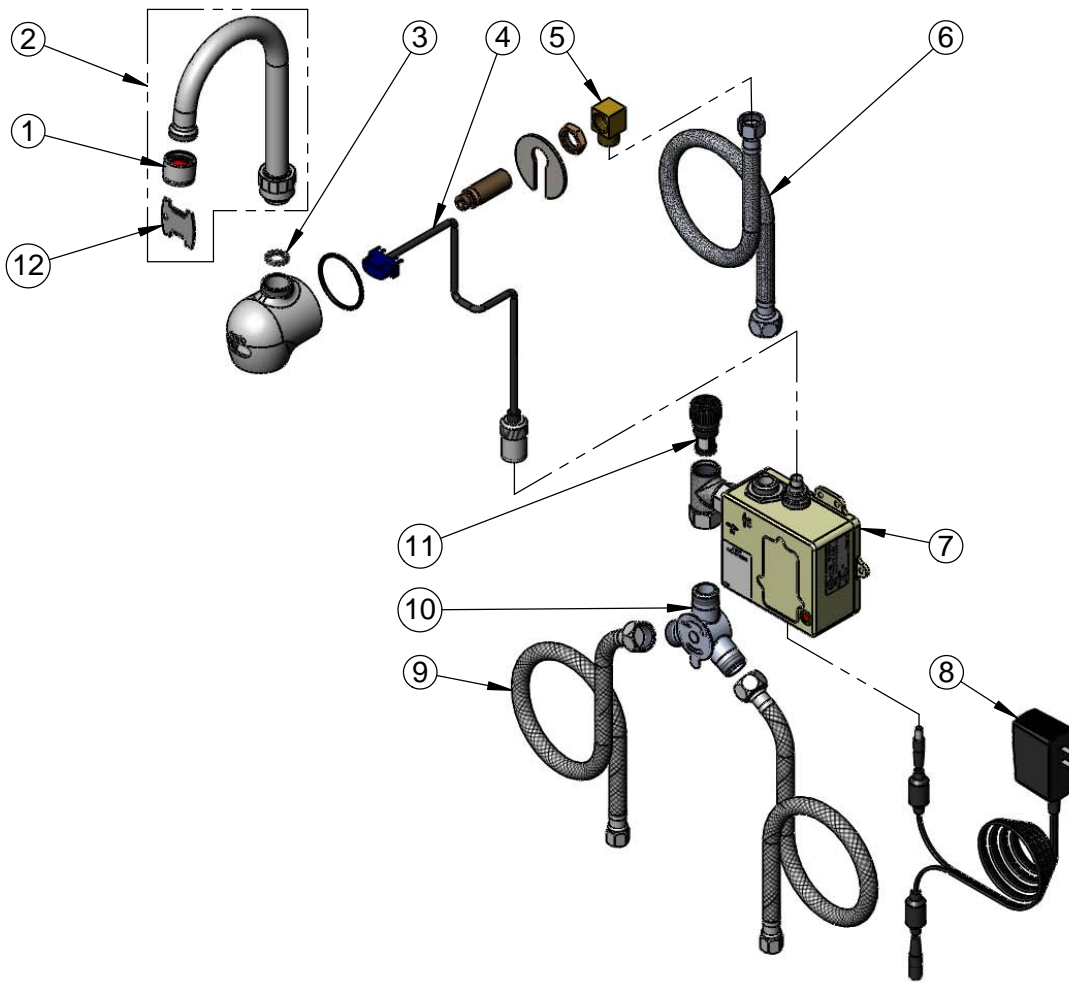

Model Number 5EF-1D-WGAT	Date 03/18/13	Scale NTS	Drawn DHL	Checked DMH	Approved JHB
-----------------------------	------------------	--------------	--------------	----------------	-----------------



Product Specifications:

Electronic Faucet: Wall Mount Swivel Gooseneck w/ 2.2 GPM VR Aerator, AC-DC Control Module, Temperature Control Mixing Valve w/ Integral Check Valves & 18" Long Flexible Supply Stop Hoses

equip Foodservice Accessories
 2 Saddleback Cove, P.O. Box 1088
 Travelers Rest, South Carolina 29690
 Phone: 800.891.4808 Fax: 800.868.0084