

ADA Compliant

This Space for Architect/Engineer Approval

Job Name _____ Date _____

Model Specified _____ Quantity _____

Customer/Wholesaler _____

Contractor _____

Architect/Engineer _____

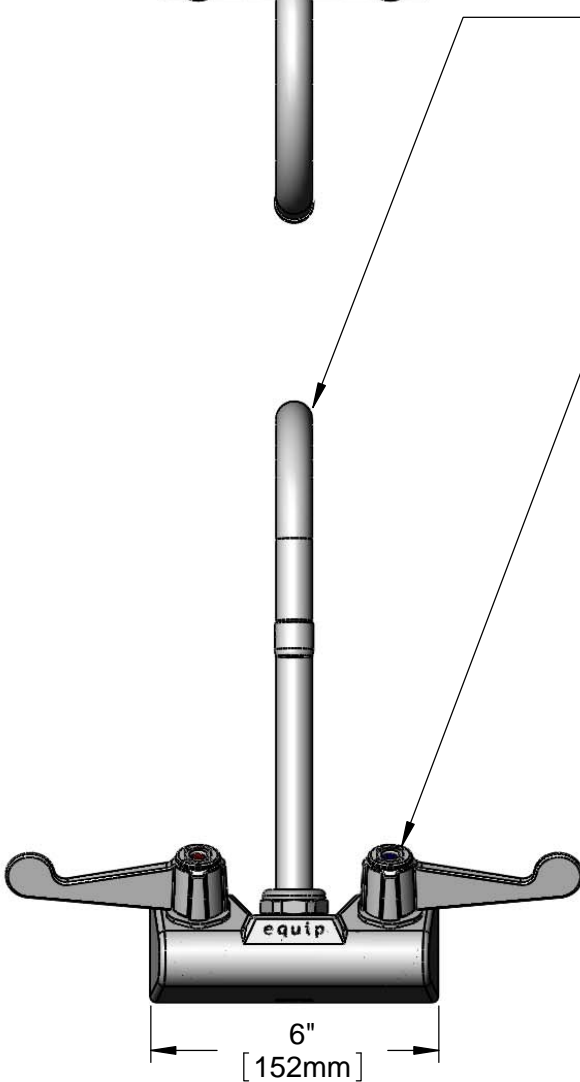

5SP-05A
equip 5 1/2" Swing Nozzle w/
2.2 GPM Aerator.
Rigid Conversion Requires
014200-45 Lock Washer
(Sold Separately)

Ceramic Cartridges &
equip 4" Wrist Action Handles
w/ Color Coded Screws

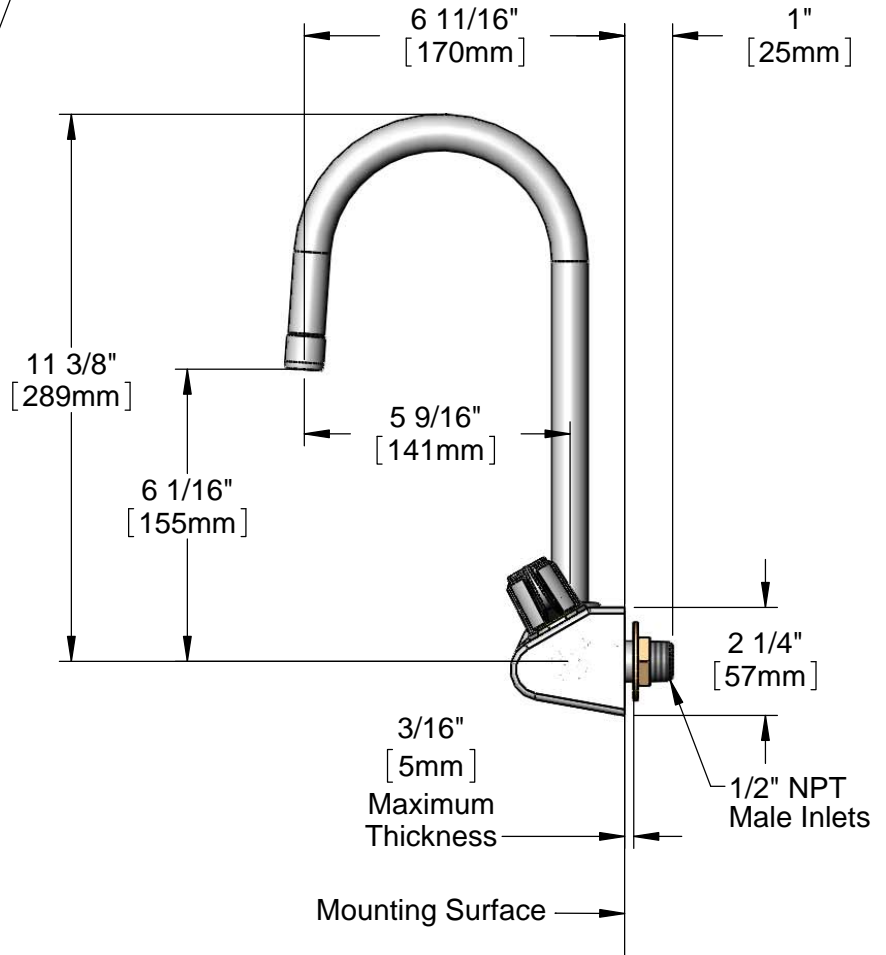
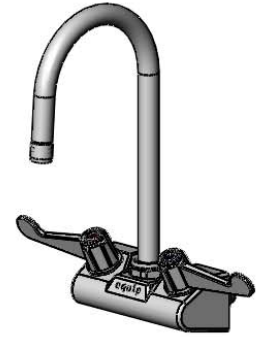

Rough-In Requirement:
(2) ϕ 1" [25mm] Mounting Holes

Model Number 5F-4WWX05	Date 06/05/12	Scale 1:4	Drawn DHL	Checked DMH	Approved JHB
---------------------------	------------------	--------------	--------------	----------------	-----------------



Product Specifications:
**4" Wall Mount Mixing Faucet w/ Ceramic Cartridges,
 equip 4" Wrist Action Handles, 5 1/2" Swing Nozzle w/
 2.2 GPM Aerator & 1/2" NPT Male Inlets**
 equip Foodservice Accessories
 2 Saddleback Cove, P.O. Box 1088
 Travelers Rest, South Carolina 29690
 Phone: 800.891.4808 Fax: 800.868.0084

ITEM NO.	SALES NO.	DESCRIPTION
1	5SP-05A	equip 5 1/2" Swing Nozzle w/ 2.2 GPM Aerator
2	013838-45	Aerator, 3/4-27 Female, 2.2 GPM
3	013839-25	equip Swivel Nut
4	013848-45	equip Swivel Piece O-ring
5	017587-45	Swivel Nut Seal
6	5-HDL-W	equip 4" Wrist Action Handle w/ Color Coded Screws
7	013788-45	equip Ceramic Cartridge, LTC
8	000999-45	Brass Lock Washer
9	002954-45	Shank Lock Nut
10	013787-45	equip Ceramic Cartridge, RTC

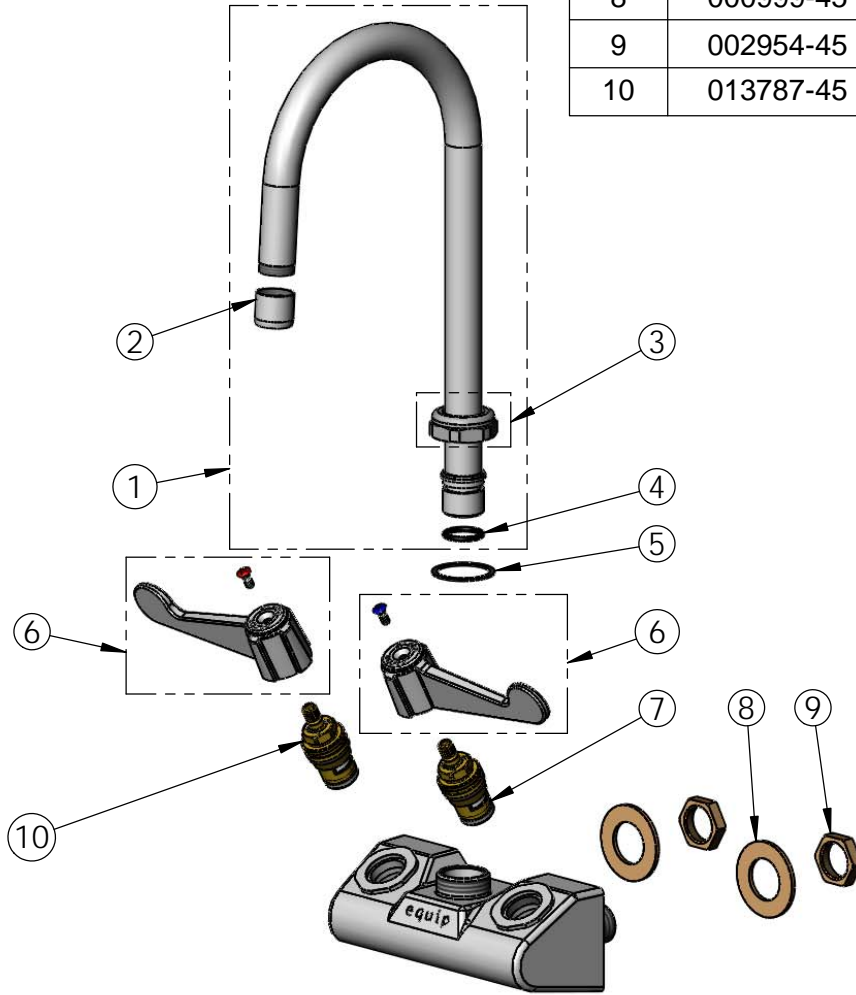

Model Number 5F-4WWX05	Date 06/05/12	Scale NTS	Drawn DHL	Checked DMH	Approved JHB
---------------------------	------------------	--------------	--------------	----------------	-----------------

	Product Specifications: 4" Wall Mount Mixing Faucet w/ Ceramic Cartridges, equip 4" Wrist Action Handles, 5 1/2" Swing Nozzle w/ 2.2 GPM Aerator & 1/2" NPT Male Inlets
	equip Foodservice Accessories 2 Saddleback Cove, P.O. Box 1088 Travelers Rest, South Carolina 29690 Phone: 800.891.4808 Fax: 800.868.0084