

This Space for Architect/Engineer Approval

Job Name _____ Date _____
Model Specified _____ Quantity _____
Customer/Wholesaler _____
Contractor _____
Architect/Engineer _____

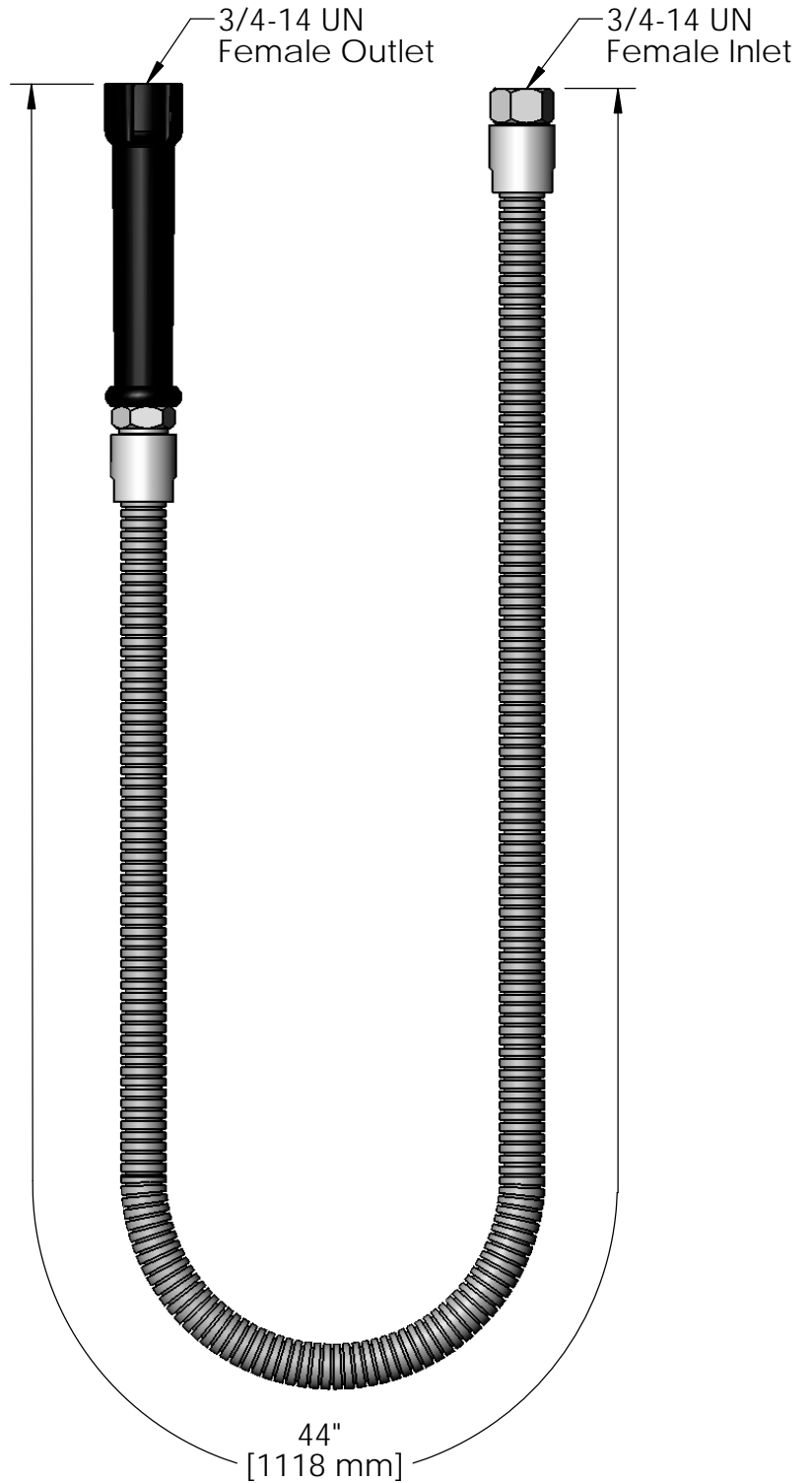

(2) 010476-45
Washers Furnished
w/ Hose

Model Number 5HSE44	Date 03/02/12	Scale 1:3	Drawn DHL	Checked KJG	Approved JHB
------------------------	------------------	--------------	--------------	----------------	-----------------



Product Specifications:

44" Stainless Steel Flex Hose w/
Black Handle & Polyurethane Inner Hose

equip Foodservice Accessories
2 Saddleback Cove, P.O. Box 1088
Travelers Rest, South Carolina 29690
Phone: 800.891.4808 Fax: 800.868.0084

ITEM NO.	SALES NO.	DESCRIPTION
1	001014-45	Washer, B-0100 Hose Barrel
2	000729-40	Nut, 7/8"-20 Male x 3/4"-14 Female
3	010476-45	#27 Washer

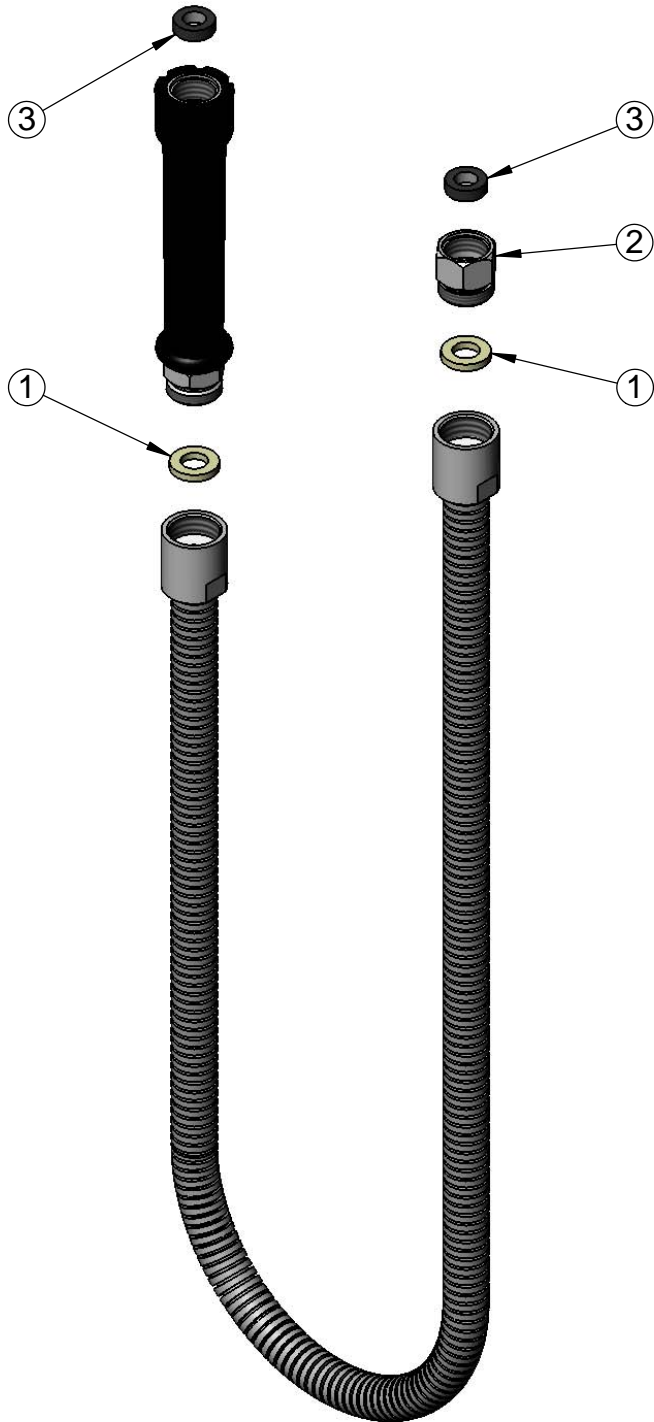

Model Number 5HSE44	Date 03/02/12	Scale NTS	Drawn DHL	Checked KJG	Approved JHB
------------------------	------------------	--------------	--------------	----------------	-----------------



Product Specifications:
44" Stainless Steel Flex Hose w/
Black Handle & Polyurethane Inner Hose

equip Foodservice Accessories
2 Saddleback Cove, P.O. Box 1088
Travelers Rest, South Carolina 29690
Phone: 800.891.4808 Fax: 800.868.0084