



T&S BRASS AND BRONZE WORKS, INC.

2 Saddleback Cove / P.O. Box 1088
Travelers Rest, SC 29690



REG. #A2601
ISO #9001

Model No.

B-0504-SL

Item No.

Travelers Rest, SC: 800-476-4103 Simi Valley, CA: 800-423-0150 Fax: 864-834-3518 www.tsbrass.com

This Space for Architect/Engineer Approval

Job Name _____ Date _____

Model Specified _____ Quantity _____

Customer/Wholesaler _____

Contractor _____

Architect/Engineer _____

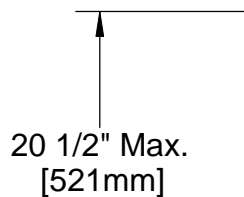
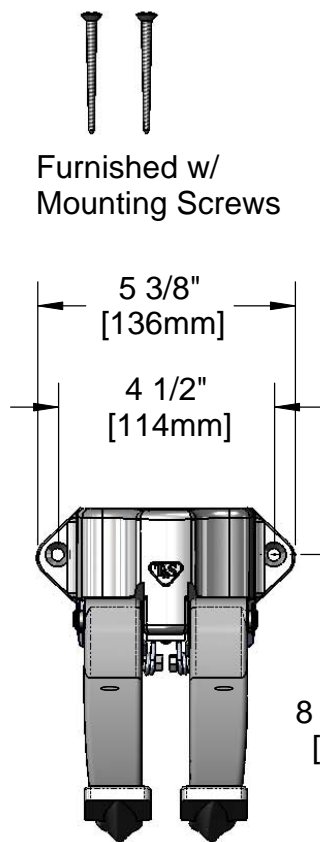
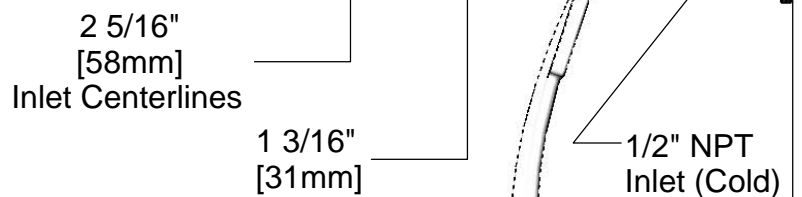
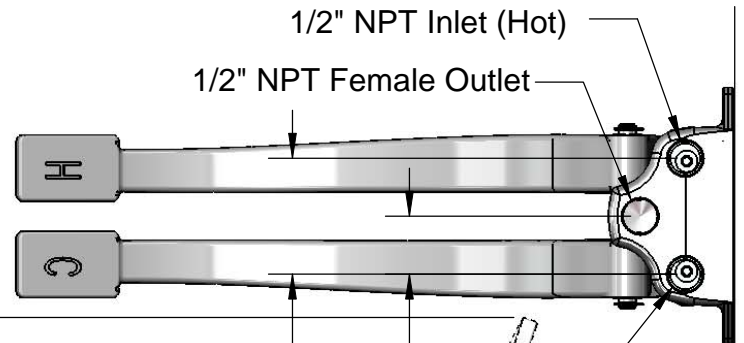

Adjustable from 4 7/16" [113mm] to 7" [178mm] When Valve is Closed. 1 3/8" [35mm] to 3 1/8" [79mm] When Valve is Opened.

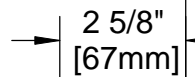

Pedal Height Adjustment Screws

Note: All Pedal Position Dimensions are Based on a Recommended Min. Mtg. Height of 8 3/4" [222mm] Above Fin. Floor.

Adjustable from 15 3/16" [386mm] to 15 1/2" [394mm] When Valve is Closed. 14 5/16" [363mm] to 15" [381mm] When Valve is Opened.

Product Specifications:
Double Pedal Valve w/ Metering Cartridges

Drawn
DHL

Checked
JRM

Approved
JHB

Scale:

1:4

Date:

01/28/09



T&S BRASS AND BRONZE WORKS, INC.

2 Saddleback Cove / P.O. Box 1088
Travelers Rest, SC 29690



REG. #A2601
ISO #9001

Model No.

B-0504-SL

Item No.

Travelers Rest, SC: 800-476-4103 Simi Valley, CA: 800-423-0150 Fax: 864-834-3518 www.tsbrass.com

ITEM NO.	SALES NO.	DESCRIPTION
1	000240-30	Pedal (Hot)
2	012512-45	E-clip Retaining Ring
3	001602-45	Bushing, Pedal Valve
4	003749-45	Foot Pedal Mtg. Screw
5	000886-45	Spring, LH (Hot Pedal)
6	001483-25	Screw & Spacer, Pedal Spring
7	012513-10	Pad
8	011320-25	Adapter
9	011406-40	Metering Assembly
10	012523-45	Screw
11	000887-45	Spring, RH (Cold Pedal)
12	000952-45	Nut
13	001123-45	Nylon Set Screw
14	000239-30	Pedal (Cold)

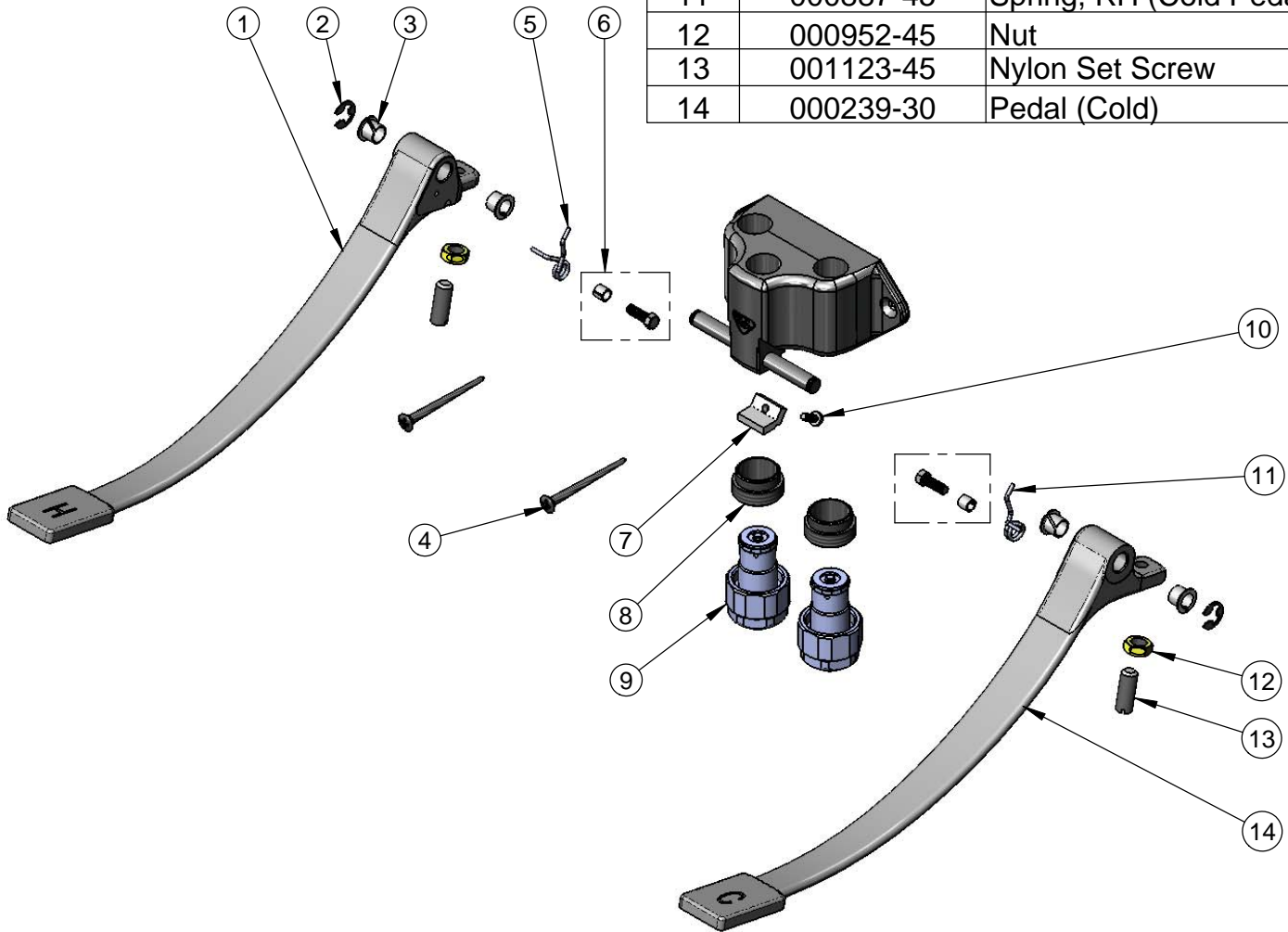

Product Specifications:

Double Pedal Valve w/ Metering Cartridges

Drawn DHL	Checked JRM	Approved JHB
Scale: NTS		Date: 01/28/09