

INCHES 1 2 3 4 5

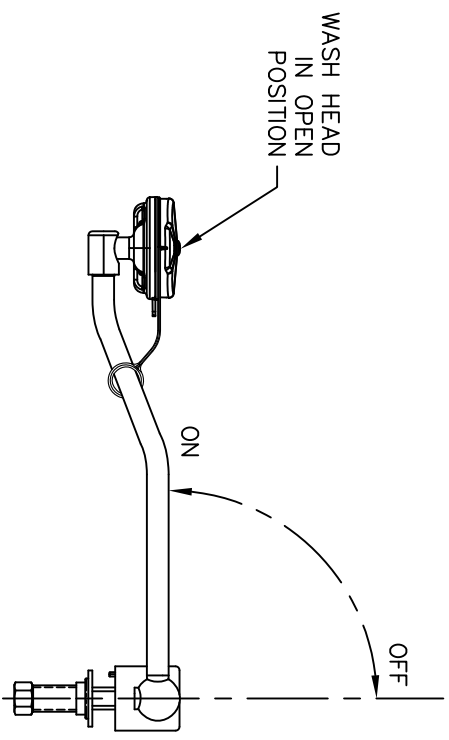
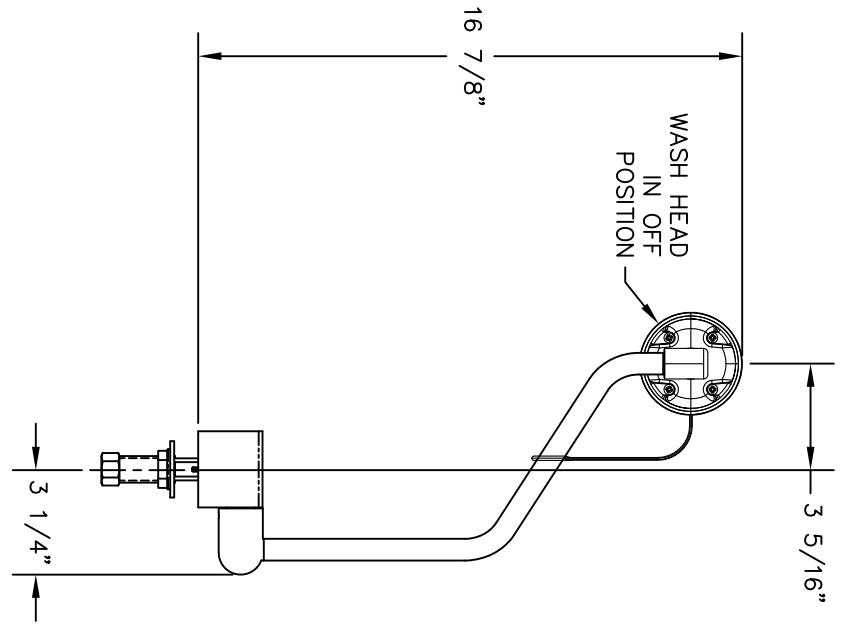

- NOTES:
- ◇ 1. DIMENSIONS SHOWN ARE REFERENCE.
 - 2. CERTIFIED TO ANSI STANDARD Z358.1 (LATEST REVISION).
 - ◇ 3. HAWS CORPORATION MODEL NO. 7610.

THIS DRAWING CONTAINS PROPRIETARY INFORMATION AND IS THE PROPERTY OF T&S BRASS AND BRONZE WORKS, INC. REPRODUCTION OF THIS DRAWING WITHOUT THE WRITTEN PERMISSION FROM T&S IS PROHIBITED.		TOLERANCES UNLESS OTHERWISE SPECIFIED XXX ±.010 CONC. .010 TIR XXX ±.005 FRAC. 1/4" ANGLES ±1/2° CHAMFERS 45° ALL SHARP EDGES. 0.05" MAX.		MACHINE FINISH UNLESS OTHERWISE SPECIFIED SURFACE FINISH: 63 REMOVE ALL BURRS AND BREAK ANGLES ±1/2° CHAMFERS 45° ALL SHARP EDGES. 0.05" MAX.	
DATE	DESCRIPTION	ECO	REVISIONS	T&S BRASS AND BRONZE WORKS, INC. P.O. BOX 1188 2 SADDLEBACK COVE TRAVELERS REST SOUTH CAROLINA 29590	
01/22/09	INITIAL RELEASE	13861	1	DRAWN ARH 1/15/09 CHECKED JRM 1/22/09 APPROVED JHB 1/22/09 TITLE EYEWASH, PULL DOWN (PURCHASE)	
12/20/10	HAWS STD PRODUCT	14301	1	FINISH N/A MATERIAL N/A DRAWING NUMBER EW-7610 SCALE 1:8 SHEET 1 OF 1	