



1250 Victoria St  
 Carson, CA 90746  
 Tel. 310-900-1000  
 Fax. 310-900-1077  
[www.turboairinc.com](http://www.turboairinc.com)

Project :	
Model # :	
Item # :	Qty :
Available W/H :	
Approval :	

## Meat Saws

**HIGH QUALITY STAINLESS STEEL  
 INTERIOR AND FRAME**

**Model : GBS-450S**

### ≡ FEATURES / BENEFITS ≡

#### ■ ALL STAINLESS STEEL INTERNAL PARTS

All of the internal metal parts including the upper wheel, lower wheel, upper wheel hinge and the lower bearing housing are made with stainless steel.

#### ■ ELECTRICAL CONTROL SYSTEM

The magnetic switch system ensures consistent electrical contact which provides safety through dynamic braking and automatic overload protection.

#### ■ FRAME MATERIALS

All frame and food contact parts are made with either stainless steel (GBS-270S, GBS-450S) or aluminum (GBS-230A) providing improved durability and sanitation.

#### ■ MOTOR

The motor produces less heat and runs at a lower temperature by using a type "A" grade insulation. The motor also uses a cooling fan to reduce the possibility of overheating and an automatic over temperature shutdown sensor to prevent damage.

#### ■ PROTECTION AGAINST WATER DAMAGE

The upper wheel assembly and the lower bearing housing assembly are sealed against water damage allowing faster clean up and protection when cutting wet products.

#### ■ MOTOR DRIVE

The motor delivers power to the lower wheel through a V-belt drive system resulting in minimal vibration and noise. The motor is designed to maintain a high torque even at normal running speed.

#### ■ SAFETY

A rolling table and hand guard provide safe and sanitary operation. If the door opens during operation, the installed sensor automatically shuts off the power.

#### ■ CLEANING

Both the upper and lower wheels have cleaning devices insuring improved durability and sanitation. The door is hinged and easily removed for cleaning. The installed scrap box allows quick removal of waste.

#### ■ THICKNESS ADJUSTING

The scaled shaft of the thickness adjusting plate allows a standardized and consistent product cut.



Model	HP	Length of Saw Blade (inches)	Crated Weight (lbs.)	L x D x H (inches)
<b>GBS-450S</b>	<b>3</b>	<b>126</b>	<b>729</b>	<b>46 x 37 1/2 x 83 3/4</b>

# Meat Saws

HIGH QUALITY STAINLESS STEEL  
INTERIOR AND FRAME

## Model : GBS-450S

ELECTRICAL DATA	
Motor	3 HP
Power Voltage	AC208V • 60Hz • 3Phase
Saw Blade Speed	5,000 ft/min
DIMENSIONAL DATA	
Ext. Length Overall in.	37 <sup>1</sup> / <sub>2</sub>
Ext. Depth Overall in.	46
Ext. Height Overall in.	83 <sup>3</sup> / <sub>4</sub>
Length of Saw Blade	126
Gross Weight lbs.	729
Loading Dimension (L x H)	15 <sup>1</sup> / <sub>2</sub> x 18 <sup>3</sup> / <sub>8</sub>
Work Table (W x D)	34 x 36
Switch	Tow Hands Start
Drive	Non Slip V-Belt

Design and specifications subject to change without notice.  
Actual shipping weight may differ due to extra packing materials for product protection.

■ **WARRANTY : 2 Year Parts and Labor Warranty**

### PLAN VIEW

(unit : inch)

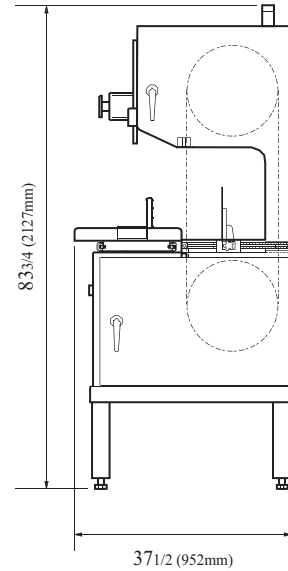

FRONT VIEW

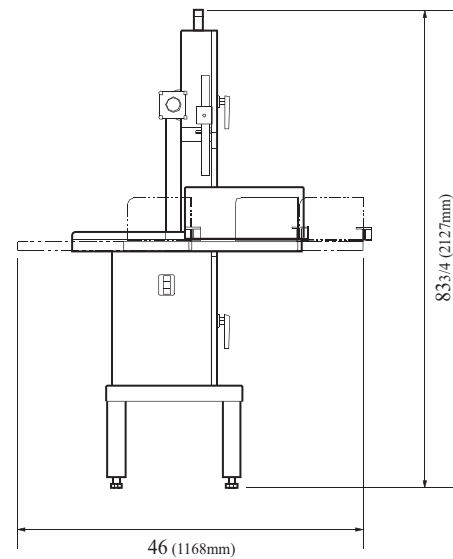

SIDE VIEW

Ver.201210



■ Turbo Air : 800-627-0032 ■ GK : 800-500-3519  
■ Warranty : 800-381-7770 ■ AC : 888-900-1002