

**REFRIGERATOR MANUFACTURER**  
**Turbo air**  
 more durable, convenient, beautiful

1250 Victoria St  
 Carson, CA 90746  
 Tel. 310-900-1000  
 Fax. 310-900-1077  
[www.turboairinc.com](http://www.turboairinc.com)

|                 |       |
|-----------------|-------|
| Project :       |       |
| Model # :       |       |
| Item # :        | Qty : |
| Available W/H : |       |
| Approval :      |       |

## Soild Door Freezer

Reach-In Top Mounts  
**PREMIERE Series**

**Model : PRO-77F**

### FEATURES / BENEFITS

- **DIGITAL TEMPERATURE CONTROL SYSTEM**  
 Provides precise and constant temperature. This level of precision allows food products to remain fresh over an extended period of time.
- **HIGH-TECH MONITOR**  
 The unit will beep if the door has been opened for more than 30 seconds. The monitor digitally displays the present temperature and current status of the freezer. You can easily change the temperature by adjusting the thermostat.
- **ALL STAINLESS STEEL CABINET CONSTRUCTION**  
 The Turbo Air Premiere model boasts all stainless steel interior and exterior (galvanized steel top, bottom and back). It guarantees the utmost in cleanliness and long product life. Unlike other companies' products, the sharp corners and edges have been rounded to reduce the risk of injury. The Premiere can add a touch of style to the most refined setting.
- **STURDY, CLEAN STAINLESS SHELVING**  
 Shelves are the most important part of cleanliness as they come in direct contact with food. After a while, PVC coated wire shelves may peel, rust and lead to unsanitary conditions. Only the Turbo Air Premiere series uniquely provides stainless shelving.
- **HOT GAS CONDENSATE SYSTEM**  
 Through Turbo Air's creative innovation, the condensate system surfaces have been specially treated to resist corrosion. This not only increases efficiency without the risk of refrigerant leakage from corrosion, but thoroughly prevents the overflow of condensate water.
- **EFFICIENT REFRIGERATION SYSTEM**  
 Premiere's solid door freezers are designed with oversized and balanced (CFC Free R-404A) refrigeration systems. These include efficient evaporators and condensers for faster freezing and greater efficiency.
- **AUTOMATIC EVAPORATOR FAN MOTOR DELAYS**  
 Through stopping the evaporator fan when the freezer door opens, the circulation of hot, moist air into the freezer is prevented. This increases energy efficiency and lengthens the life of the compressor.
- **HIGH-DENSITY POLYURETHANE INSULATION**  
 The entire cabinet structure and solid doors are foamed-in-place using high density, CFC free polyurethane insulation.
- **ERGONOMICALLY DESIGNED DOORS**  
 Customers' fatigue fades away with easy grip handles and doors that open effortlessly. Self-closing and stay open door features make this the ultimate choice in customer convenience.
- **MAGNETIC DOOR GASKETS**  
 Magnetic door gaskets are of one piece construction, removable without tools for ease of cleaning and replacement.
- **TOP MOUNT COMPRESSOR UNITS**  
 Premiere's top mount refrigeration system has positioned the evaporator out of the food zone to maximize capacity.

**EXCEPTIONAL 3 YEAR  
 PARTS & LABOR WARRANTY**



**FREEZER HOLDS -10°F ~ 0°F FOR THE  
 BEST IN FROZEN FOOD PRESERVATION**



| Model          | Swing Door | CU./FT.   | #of Shelves | HP           | AMPS        | Crated Weight (lbs.) | L x D x H* (inches)         |
|----------------|------------|-----------|-------------|--------------|-------------|----------------------|-----------------------------|
| <b>PRO-77F</b> | <b>3</b>   | <b>77</b> | <b>9</b>    | <b>1 1/2</b> | <b>13.8</b> | <b>740</b>           | <b>77 3/4 x 33 7/8 x 78</b> |

## Model : PRO-77F

| ELECTRICAL DATA          |   |
|--------------------------|---|
| Voltage †                | 115/208~230/60/1                                |
| Plug Type †              | Ⓢ NEMA-L14-20                                   |
| Full Load Amperes        | 13.8  |
| Compressor HP            | 1 1/2   |
| Feed Wires with Ground   | 4   |
| Cord Length ft.          | 9   |
| Refrigerant              | R-404A  |
| DIMENSIONAL DATA         |   |
| # of Doors               | 3   |
| # of Racks Accepted      | 3   |
| Net Capacity cu. ft.     | 77  |
| Ext. Length Overall in.  | 77 3/4 (1975mm)                                 |
| Ext. Depth Overall in.   | 33 7/8 (861mm)                                  |
| Ext. Height Overall in.* | 78 (1981mm)                                     |
| Int. Length Overall in.  | 73 7/8 (1877mm)                                 |
| Int. Depth Overall in.   | 27 3/4 (705mm)                                  |
| Int. Height Overall in.  | 60 5/8 (1539mm)                                 |
| Gross Weight lbs.        | 740   |
| # of Shelves             | 9   |
| Shelf Size (LxD) in.     | 26 1/2 x 25 1/4 26 1/2 x 23 1/8 26 1/2 x 25 1/4 |

Design and specifications subject to change without notice.  
Actual shipping weight may differ due to extra packing materials for product protection.  
\* Height does not include 5" caster height or 6" optional legs.  
† PRO-77F requires 115/208-230/60Hz, single phase, 3 pole, 4 wire circuit. (NEMA-L14-20)

■ **WARRANTY :** Exceptional 3 Year Parts and Labor Warranty  
Additional 2 Year Warranty on Compressor

- INCANDESCENT INTERIOR LIGHTING
- MINIMUM WATTAGE HEATER IN CABINET FRAME
- DOOR LOCKS
- SELF-CONTAINED SYSTEM
- 4" SWIVEL CASTERS
- SOLID AND STURDY GRILLE DESIGN
- TRAY RACK AVAILABLE (OPTIONAL)

■ **OPTIONAL ACCESSORIES :**

- 5" Diameter swivel casters
- 6" Standard legs
- Additional stainless steel shelves
- Additional PE coated wire shelves
- Half door bun tray racks. Each holds up to seven 18"Lx26"D sheet pans (sold separately)
- Full door bun tray racks. Each holds up to fifteen 18"Lx26"D sheet pans (sold separately)

## PLAN VIEW

(unit : inch)

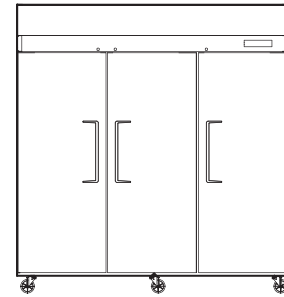

FRONT VIEW

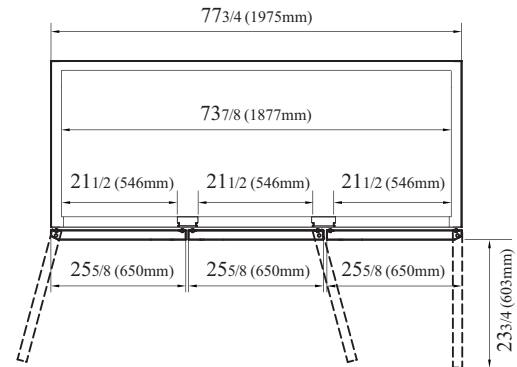

PLAN VIEW

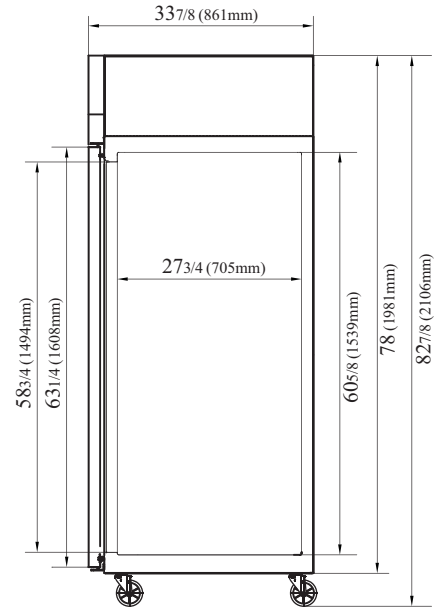

SIDE VIEW

Ver.201203



ENERGY STAR®  
Qualified

- Turbo Air : 800-627-0032
- GK : 800-500-3519
- Warranty : 800-381-7770
- AC : 888-900-1002