



4184 E. Conant st., Long Beach, CA 90808  
 Tel. 800-500-3519 Fax. 310-900-1066  
[www.turboairinc.com](http://www.turboairinc.com)

Project :

Model # :

Item # :

Qty :

Available W/H :

Approval :

## Cheesemelters

**Model : TACM-24**



### ≡ FEATURES & BENEFITS ≡

- *Stainless steel front & sides*
- *Adjustable gas valve*
- *Protective screen over infra-red burner*
- *Chrome plated heavy duty rack*
- *Unit can be mounted over Radiance range, counter and also on a wall*
- *CSA certified for safety / sanitation for USA and Canada*



Model	Weight (lbs.)	Length (inches)	Total BTUs
TACM-24	105	24	20,000
TACM-24-LP	105	24	20,000

# Cheesemelters

## Model : TACM-24

DATA	TACM-24	TACM-24-LP
Gas Type	NAT	LPG
Gas Connection	3/4"	3/4"
Regulator	1	1
Gas Pressure	5.W.C"	10.W.C"
<b>DIMENSIONAL DATA</b>		
Ext. Length Overall (inch)	24 (610mm)	24 (610mm)
Ext. Depth Overall (inch)	20 1/2 (519mm)	20 1/2 (519mm)
Ext. Height Overall (inch)	19 (483mm)	19 (483mm)

Design and specifications subject to change without notice.  
Actual shipping weight may differ due to extra packing materials for product protection.

■ **WARRANTY : 1 Year Parts and Labor Warranty**

## PLAN VIEW

(unit : inch)

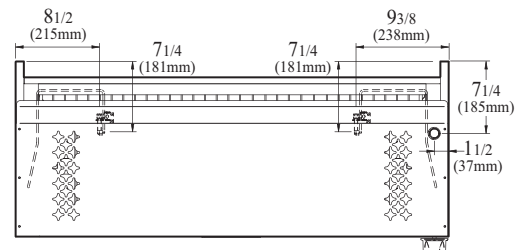

TOP VIEW

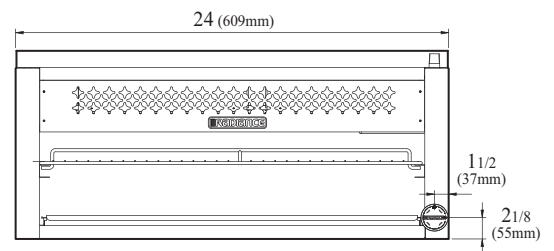

FRONT VIEW

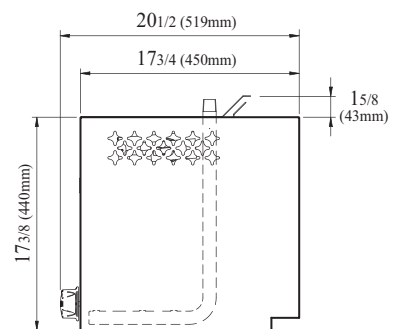

SIDE VIEW

Ver.201501



- Turbo Air : 800-627-0032 ■ GK : 800-500-3519
- Warranty : 800-381-7770 ■ AC : 888-900-1002