



4184 E. Conant st., Long Beach, CA 90808
 Tel. 310-900-1000 Fax. 310-900-1077
www.turboairinc.com

Project :

Model # :

Item # :

Qty :

Available W/H :

Approval :

Heavy Duty Stock Pot Stoves

Model : TASP-D



TASP-18-D



TASP-18S-D

≡ FEATURES / BENEFITS ≡

- HIGH QUALITY STAINLESS STEEL FRONT AND SIDES
- CAST-IRON 3 RING BURNER WITH 2 CONTROL KNOB
- HIGH PERFORMANCE 79,000 BTU/HR PER BURNER
- REMOVABLE 21" X 18" HEAVY CAST-IRON TOP GRATES
- REMOVABLE FULL WIDTH GREASE PAN
- ERGONOMICALLY DESIGNED HEAT RESISTANT PPS (POLY PHENYLENE SULFIDE) ON-OFF KNOB
- ADJUSTABLE STAINLESS STEEL STANDING PILOT FOR EACH BURNER
- 3/4" REAR GAS CONNECTION AND GAS PRESSURE REGULATOR
- 6" STAINLESS STEEL LEGS INCLUDED
- AVAILABLE IN 24" HIGH AND 18" HIGH



Model	#of Burners	Total BTUs	Crated Weight (lbs.)	W x D x H (inches)
TASP-18-D	3-Ring	158,000	230	18 x 41 1/2 x 24
TASP-18S-D	3-Ring	158,000	220	18 x 41 1/2 x 18

Heavy Duty Stock Pot Stoves

Model : TASP-D

GAS DATA	TASP-18-D	TASP-18S-D
Gas Type	NAT/LP Convertible	NAT/LP Convertible
Gas Connection	3/4"	3/4"
Regulator	3/4"	3/4"
Gas Pressure	NAT : 5W.C" / LP : 10W.C"	
SHIPPING DATA		
Class	70	70
Length (in.)	18 (457mm)	18 (457mm)
Depth (in.)*	41 1/2 (1055mm)	41 1/2 (1055mm)
Height (in.)	24 (610mm)	18 (457mm)
Shipping Weight (lbs.)	230	220

Design and specifications subject to change without notice.

Actual shipping weight may differ due to extra packing materials for product protection.

* Depth does not include 3/4" for rear gas connection and 2" for control knob.

■ WARRANTY : 1 Year Parts and Labor Warranty

(unit : inch) **PLAN VIEW**

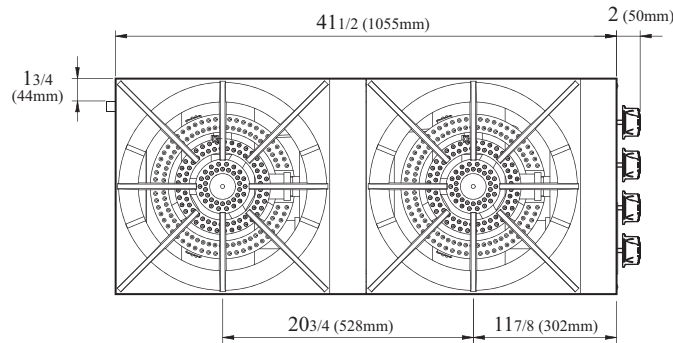

TOP VIEW

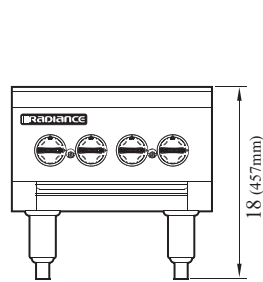

TASP-18S-D

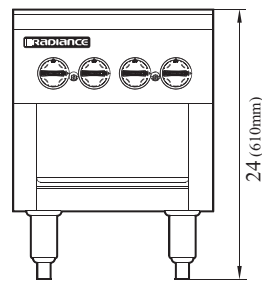

TASP-18-D

FRONT VIEW

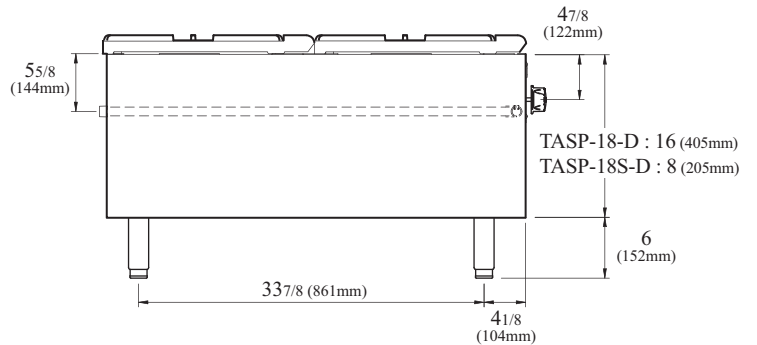

SIDE VIEW

Ver.201401



- Turbo Air : 800-627-0032 ■ GK : 800-500-3519
- Warranty : 800-381-7770 ■ AC : 888-900-1002