

**REFRIGERATOR MANUFACTURER**  
**Turbo air**  
 more durable, efficient, beautiful

4184 E. Conant St.  
 Long Beach, CA 90808  
 Tel. 310-900-1000  
 Fax. 310-900-1077  
[www.turboairinc.com](http://www.turboairinc.com)

Project :	
Model # :	
Item # :	Qty :
Available W/H :	
Approval :	

## Chef Base

*Chef Bases  
 Super Deluxe Series*

**3 YEAR PARTS & LABOR WARRANTY**

**Model : TCBE-36SDR**



- Drawer Pans Not Included

### FEATURES / BENEFITS

- STRONG BODY AND DURABLE CONSTRUCTION**  
 Built with heavy duty, 304 stainless steel (16 gauges) Chef Base top is manufactured of one-piece reinforced stainless steel to ensure durability.
- DURABLE STAINLESS STEEL DRAWERS**  
 Drawers are easy to clean and assemble.
- TOP IS INSULATED TO ELIMINATE HEAT TRANSFER TO THE INTERIOR OF CABINET**
- EFFICIENT REFRIGERATION SYSTEM**  
 Turbo Air's solid door refrigerators are designed with oversized and balanced (CFC Free R-134A) refrigeration systems. These include efficient evaporators and condensers for faster cooling and greater efficiency.
- HIGH-DENSITY POLYURETHANE INSULATION**  
 The entire cabinet structure and solid doors are foamed-in-place using high density, CFC free polyurethane insulation.
- SIDE MOUNT COMPRESSOR UNIT**  
 By positioning the compressor on the side of the unit, refrigerators can now be serviced without being moved. Our innovative, front breathing feature also allows this model to provide high efficiency in narrow spaces.
- REFRIGERATOR HOLDS 33°F ~ 38°F FOR THE BEST IN FOOD PRESERVATION**



Model	Drawers	CU./FT.	Countertop Weight Capacity (lbs.)	HP	AMPS	Crated Weight (lbs.)	L x D x H* (inches)
TCBE-36SDR	2	6.1	788	1/4	2.8	229	35 5/8 x 32 x 20 1/2

## Model : TCBE-36SDR

ELECTRICAL DATA	
Voltage	115/60/1
Plug Type	Ⓜ NEMA-5-15P
Full Load Amperes	2.8
Compressor HP	1/4
Cord Length ft.	9
Refrigerant	R-134A
DIMENSIONAL DATA	
Ext. Length Overall in.	35 <sup>5</sup> / <sub>8</sub> (904mm)
Ext. Depth Overall in.	32 (813mm)
Ext. Height Overall in.*	20 <sup>1</sup> / <sub>2</sub> (521mm)
# of Drawers	2
# of Pans	18
Net Capacity cu. ft.	6.1
Gross Weight lbs.	?
Net Weight lbs.	163

Design and specifications subject to change without notice.

Actual shipping weight may differ due to extra packing materials for product protection.

\* Height does not include 5-7/8" for caster height.

- **WARRANTY : 3 Year Parts and Labor Warranty**  
Additional 2 Year Warranty on Compressor

- SELF-CONTAINED SYSTEM
- 5" SWIVEL CASTERS
- LEGS AVAILABLE FOR ALL MODELS (OPTIONAL)

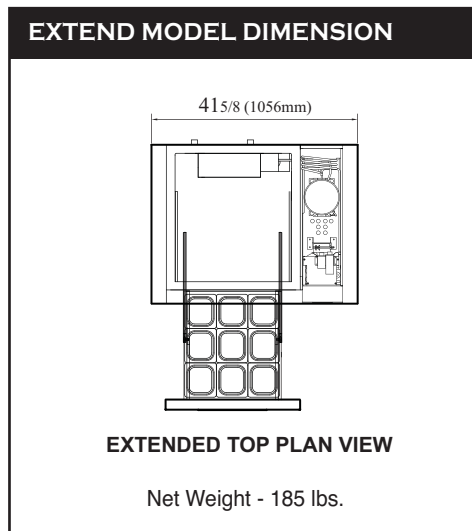

## PLAN VIEW

(unit : inch)

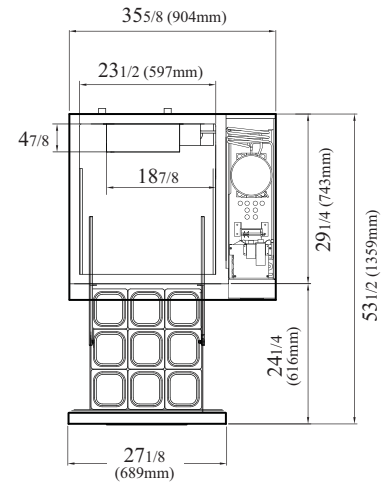

PLAN VIEW

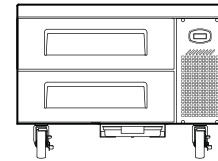

FRONT VIEW

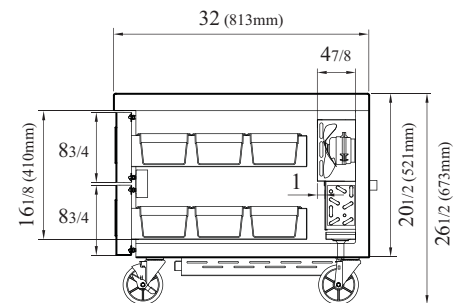

SIDE VIEW

Ver.201404



- Turbo Air : 800-627-0032
- GK : 800-500-3519
- Warranty : 800-381-7770
- AC : 888-900-1002