

**REFRIGERATOR MANUFACTURER**  
**Turbo air**  
 more durable, efficient, beautiful

4184 E. Conant St.  
 Long Beach, CA 90808  
 Tel. 310-900-1000  
 Fax. 310-900-1077  
[www.turboairinc.com](http://www.turboairinc.com)

Project :	
Model # :	
Item # :	Qty :
Available W/H :	
Approval :	

## Chef Base (Extended Top)

*Chef Bases  
 Super Deluxe Series*

**3 YEAR PARTS & LABOR  
 WARRANTY**

**Model : TCBE-72SDR  
 TCBE-72SDR-E**



TCBE-72SDR-E

- Each drawer accomodates  
 up to 4" deep sixth (1/6) size pans  
 (drawer pans not included)



TCBE-72SDR

### ≡ FEATURES & BENEFITS ≡

- **Strong body and durable construction**  
 Built with heavy duty, 304 stainless steel (16 gauges) Chef Base top is manufactured of one-piece reinforced stainless steel to ensure durability.
- **Drawers**  
 Small drawer holds up to 154 pounds.  
 Large drawer holds up to 242 pounds.
- **Countertops**  
 TCBE-36 / 48 / 52SDR support up to 788 pounds of equipment.  
 TCBE-72 / 82SDR support up to 1,192 pounds of equipment.  
 TCBE-96SDR supports up to 1,435 pounds of equipment.
- **Durable stainless steel drawers**
- **Top is insulated to eliminate heat transfer to the interior of cabinet**
- **Efficient refrigeration system**  
 Turbo Air's solid door refrigerators are designed with oversized and balanced (CFC Free R-134A) refrigeration systems. These include efficient evaporators and condensers for faster cooling and greater efficiency.
- **Side mount compressor unit**  
 By positioning the compressor on the side of the unit, refrigerators can now be serviced without being moved. Our innovative, front breathing feature also allows this model to provide high efficiency in narrow spaces.
- **High-density polyurethane insulation**  
 The entire cabinet structure and solid doors are foamed-in-place using high density, CFC free polyurethane insulation.
- **Refrigerator holds 33°F ~ 38°F for the best in food preservation**



Model	Drawers	CU./FT.	Countertop Weight Capacity (lbs.)	HP	AMPS	Crated Weight (lbs.)	L x D x H* (inches)
TCBE-72SDR	4	15.1	1192	1/3	4.5	418	72 x 32 x 20 1/2
TCBE-72SDR-E	4	15.1	1192	1/3	4.5	438	78 x 32 x 20 1/2

ELECTRICAL DATA	TCBE-72SDR	TCBE-72SDR-E
Voltage	115/60/1	115/60/1
Plug Type	Ⓜ NEMA 5-15P	Ⓜ NEMA 5-15P
Full Load Amperes	4.5	4.5
Compressor HP	1/3	1/3
Cord Length ft.	9	9
Refrigerant	R-134A	R-134A
DIMENSIONAL DATA		
Ext. Length Overall in.	72 (1829mm)	78 (1981mm)
Ext. Depth Overall in.	32 (813mm)	32 (813mm)
Ext. Height Overall in.*	20 1/2 (521mm)	20 1/2 (521mm)
# of Drawers	4	4
# of Pans	48	48
Net Capacity cu. ft.	15.1	15.1
Net Weight lbs	352	374
Gross Weight lbs..	418	440

Design and specifications subject to change without notice.  
Actual shipping weight may differ due to extra packing materials for product protection.  
\* Height does not include 5-7/8" for caster height.

■ **WARRANTY : 3 Year Parts and Labor Warranty  
Additional 2 Year Warranty on Compressor**

- **Self-contained system**
- **5" swivel casters**
- **Legs available for all models (optional)**
- **Door locks available (optional)**

## PLAN VIEW

(unit : inch)

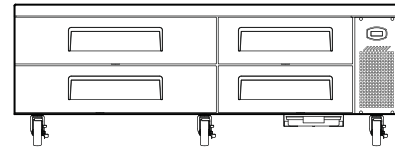

FRONT VIEW

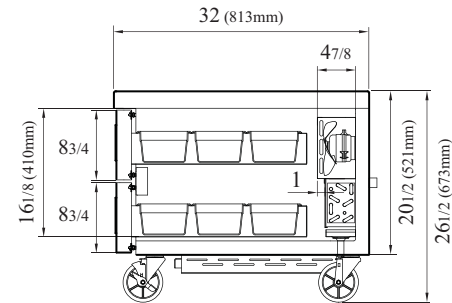

SIDE VIEW

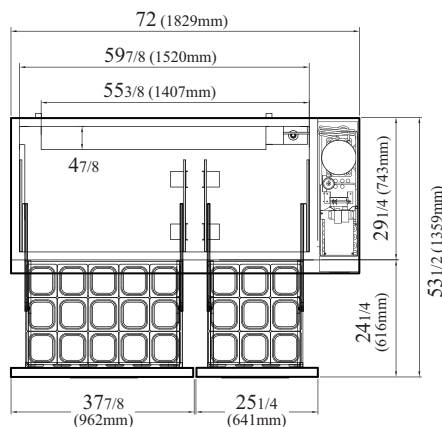

PLAN VIEW

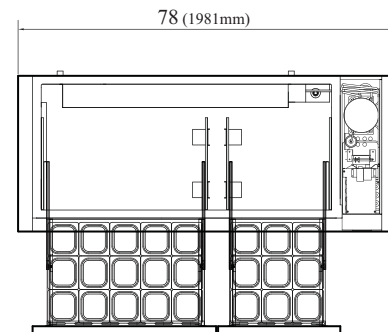

EXTENDED TOP PLAN VIEW

Ver.201501



- Turbo Air : 800-627-0032
- GK : 800-500-3519
- Warranty : 800-381-7770
- AC : 888-900-1002