

REFRIGERATOR MANUFACTURER
Turbo air
 more durable, efficient, beautiful

4184 E. Conant St.
 Long Beach, CA 90808
 Tel. 310-900-1000
 Fax. 310-900-1077
www.turboairinc.com

Project :	
Model # :	
Item # :	Qty :
Available W/H :	
Approval :	

Milk Coolers - Dual Sided Door

*Milk Coolers
 Super Deluxe Series*

**3 YEAR PARTS & LABOR
 WARRANTY**

**Model : TMKC-49D-WA
 TMKC-49D-WS
 TMKC-49D-SA
 TMKC-49D-SS**



≡ FEATURES & BENEFITS ≡

- Efficient refrigeration system**
 Turbo Air's milk coolers are designed with oversized and balanced (CFC Free R-134A) refrigeration systems. It also includes efficient evaporators and condensers for faster cooling and greater efficiency, which result in saving ownership costs. Forced-air refrigeration system keep milk cold after a prolonged period of time, allowing it to be fresh and cold.
- Exterior digital thermometer standard for easy visibility**
 Exterior digital temperature display allows easy reading, precise, and constant temperature. This level of precision allows milk to remain fresh and safe over an extended period of time.
- Sturdy and clean, durable cabinet construction**
 Exterior is stainless steel or white coated steel with stainless steel door. Interior is comprised of stainless steel.
- High-density polyurethane insulation**
 The entire cabinet construction is foamed-in-place using high density, environmental friendly CFC free polyurethane insulation.
- Convenient bottom floor drain standard with hose adapter**
 Floor drain is located in the rear on the right hand side for easy clean out. The hose adapter allows for convenient connecting to drain hose.
- Door lock standard for added safety**
- Heavy duty floor racks standard**
- Door support bumpers standard**
- Stainless steel self-service doors have drop front feature and hold-open flip-up top lid**
- 4" swivel casters standard for easy movement, two with brakes to lock the unit in place**
- Self-contained system**
- Corner bumpers available as optional**
- Dual sided for convenient access**
 Dual sided model offers convenient and efficient access to refrigerated products from both sides of the unit. Dual access milk cooler provides easy stocking and maximum serving possibility.
- Refrigerator holds 33°F ~ 38°F for the best in milk preservation**



Model	# of Doors	# of Floor Rack	CU./FT.	Crate Capacity (13 x 13 x 11)	HP	AMPS	Crated Weight (lbs.)	L x D x H [†] (inches)
TMKC-49D-**	4	2	21.0	12	1/2	7.0	353~375	49 x 32 7/8 x 41 5/8

Model : TMKC-49D-**

Model No.	
Voltage	115/60/1
Plug Type	Ⓢ NEMA 5-15P
Full Load Amperes	7.0
Compressor HP	1/2
Cord Length (ft.)	9
Refrigerant	R-134A
Net Capacity (cu. ft.)	21.0
Ext. Length (in.)	49 (1245mm)
Ext. Depth (in.)*	32 7/8 (836mm)
Ext. Height (in.)†	41 5/8 (1056mm)
# of Doors	4
Gross Weight (lbs.)	353~375
Crate Capacity (13"x13"x11")	12

Design and specifications subject to change without notice.

Actual shipping weight may differ due to extra packing materials for product protection.

* Depth does not include 5/8" (15mm) for bumpers.

† Height does not include 5" (127mm) casters.

- **WARRANTY : 3 Year Parts and Labor Warranty**
Additional 2 Year Warranty on Compressor

** Product number

Model	Gross Weight (lbs.)	EXTERIOR	INTERIOR
TMKC-49D-WA	360	White Vinyl & Stainless Steel	Aluminum
TMKC-49D-WS	375	White Vinyl & Stainless Steel	Stainless Steel
TMKC-49D-SA	353	Stainless Steel	Aluminum
TMKC-49D-SS	369	Stainless Steel	Stainless Steel

PLAN VIEW

(unit : inch)

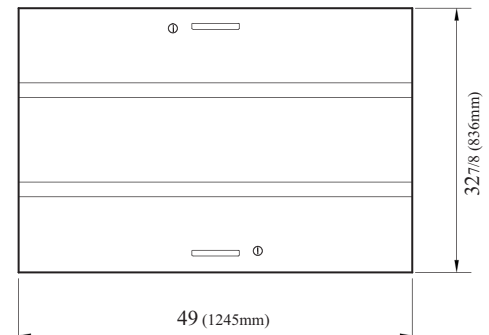

PLAN VIEW

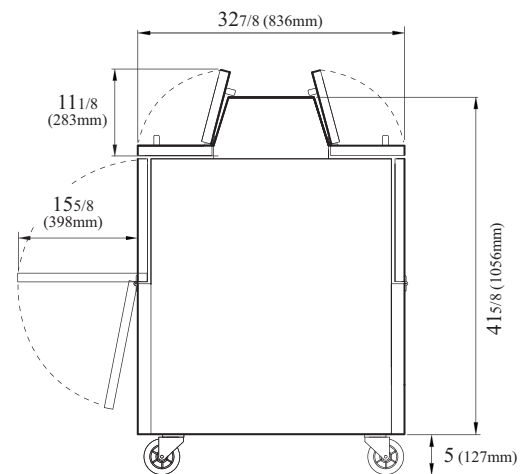

SIDE VIEW

Ver.201501



- Turbo Air : 800-627-0032 ■ GK : 800-500-3519
- Warranty : 800-381-7770 ■ AC : 888-900-1002