

REFRIGERATOR MANUFACTURER
Turbo air
 more durable, efficient, beautiful

4184 E. Conant St.
 Long Beach, CA 90808
 Tel. 310-900-1000
 Fax. 310-900-1077
www.turboairinc.com

Project :	
Model # :	
Item # :	Qty :
Available W/H :	
Approval :	

Milk Coolers

*Milk Coolers
 Super Deluxe Series*

**3 YEAR PARTS & LABOR
 WARRANTY**

Model : TMKC-58D



≡ FEATURES / BENEFITS ≡

- **EFFICIENT REFRIGERATION SYSTEM**
 Turbo Air's milk coolers are designed with oversized and balanced (CFC Free R-134A) refrigeration systems. It also includes efficient evaporators and condensers for faster cooling and greater efficiency, which result in saving ownership costs. Forced-air refrigeration system keep milk cold after a prolonged period of time, allowing it to be fresh and cold.
- **EXTERIOR DIGITAL TERMOMETER STANDARD FOR EASY VISIBILITY**
 Exterior digital temperature display allows easy reading, precise, and constant temperature. This level of precision allows milk to remain fresh and safe over an extended period of time.
- **STURDY AND CLEAN, DURABLE CABINET CONSTRUCTION**
 Exterior is stainless steel or white coated steel with stainless steel door. Interior is comprised of stainless steel.
- **HIGH-DENSITY POLYURETHANE INSULATION**
 The entire cabinet construction is foamed-in-place using high density, environmental friendly CFC free polyurethane insulation.
- **CONVENIENT BOTTOM FLOOR DRAIN STANDARD WITH HOSE ADAPTER**
 Floor drain is located in the rear on the right hand side for easy clean out. The hose adapter allows for convenient connecting to drain hose.
- **DOOR LOCK STANDARD FOR ADDED SAFETY**
- **HEAVY DUTY FLOOR RACKS STANDARD**
- **DOOR SUPPORT BUMPERS STANDARD**
- **STAINLESS STEEL SELF-SERVICE DOORS HAVE DROP FRONT FEATURE AND HOLD-OPEN FLIP-UP TOP LID**
- **REFRIGERATOR HOLDS 33°F ~ 38°F FOR THE BEST IN MILK PRESERVATION**
- **4" SWIVEL CASTERS STANDARD FOR EASY MOVEMENT, TWO WITH BRAKES TO LOCK THE UNIT IN PLACE**
- **SELF-CONTAINED SYSTEM**
- **CORNER BUMPERS AVAILABLE AS OPTIONAL**
- **DUAL SIDED FOR CONVENIENT ACCESS**
 Dual sided model offers convenient and efficient access to refrigerated products from both sides of the unit. Dual access milk cooler provides easy stocking and maximum serving possibility.



Model	# of Doors	# of Floor Rack	CU./FT.	Crate Capacity (13 x 13 x 11)	HP	AMPS	Crated Weight (lbs.)	L x D* x H† (inches)
TMKC-58D-**	4	3	24.5	16	1/2	7.0	376~403	58 x 32 7/8 x 41 5/8

Model : TMKC-58D-**

ELECTRICAL DATA	
Voltage	115/60/1
Plug Type	NEMA-5-15P
Full Load Amperes	7.0
Compressor HP	1/2
Cord Length ft.	9
Refrigerant	R134a
DIMENSIONAL DATA	
Net capacity cu.ft	24.50
Ext. Length Overall in.	58 (1475mm)
Ext. Depth Overall in.*	32 ⁷ / ₈ (836mm)
Ext. Height Overall in. †	41 ⁵ / ₈ (1056mm)
# of Doors	4
Crate Capacity (13"x13"x11")	16

Design and specifications subject to change without notice.
Actual shipping weight may differ due to extra packing materials for product protection.
* Depth does not include 5/8" (15mm) for bumpers.
† Height does not include 5" (127mm) casters.

- **WARRANTY : 3 Year Parts and Labor Warranty**
Additional 2 Year Warranty on Compressor

** Product number

Model	Gross Weight (lbs.)	EXTERIOR	INTERIOR
TMKC-58D-WA	383	White Vinyl & Stainless Steel	Aluminum
TMKC-58D-WS	403	White Vinyl & Stainless Steel	Stainless Steel
TMKC-58D-SA	376	Stainless Steel	Aluminum
TMKC-58D-SS	396	Stainless Steel	Stainless Steel

PLAN VIEW

(unit : inch)

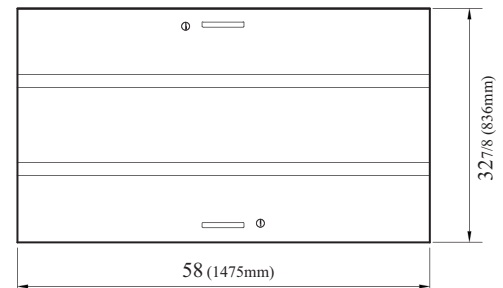

PLAN VIEW

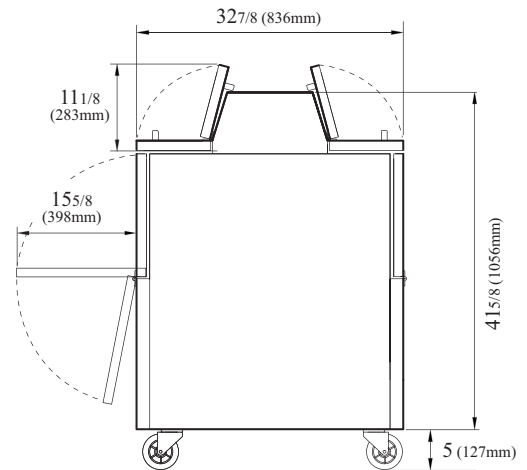

SIDE VIEW

Ver.201401



- Turbo Air : 800-627-0032
- GK : 800-500-3519
- Warranty : 800-381-7770
- AC : 888-900-1002