

Project _____

Item Number _____

Quantity _____

AHD37M



Automatic Hexagonal Divider

AHD37M (1.4oz to 5.2oz)

Features:

- Automatically divides dough
- Produces 37 equal weight and shaped pieces at once
- Can produce 3300 pieces an hour
- Strong hydraulic powered machine
- Simple controls: simply close the lid and the machine runs its cycle and automatically opens.
- Multiple languages
- Programmable control board

Production estimate is based off a 30 second start-to-finish process with prep time included



Hexagonal Divider

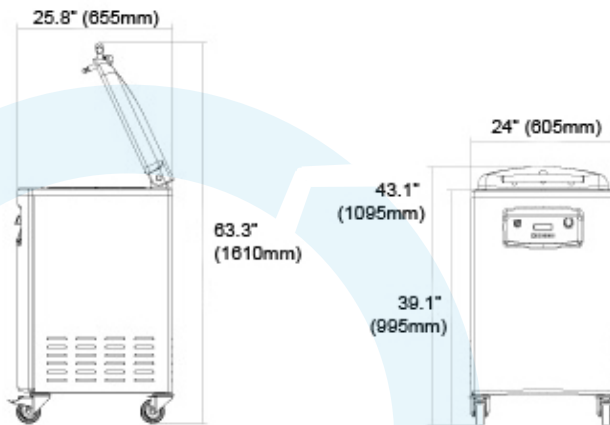

Shape Detail

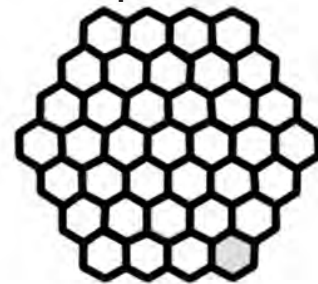

Shipping Information:

LENGTH	DEPTH	HEIGHT	WEIGHT
29.5" (750mm)	57" (1450mm)	29.5" (750mm)	507lbs (230kg)

Electrical:

220V/60Hz/3Ph

Warranty:

- One year, on-site parts and labor

Univex Corporation

Warranty Details

The MHDs carry a one year, on-site parts and labor warranty against any flaws in materials and workmanship. This period begins on the date of the purchase and, provided the unit is used in accordance with our instructions, is in full effect for one year from that date. Any work performed under this warranty must be performed between the hours of 8am and 5pm Monday through Friday. Univex will not pay for overtime charges for work performed other than during normal business hours. Damage incurred in transit or from installation error, accident, alteration or misuse is not covered. Univex shall not be liable for any consequential compensatory, incidental, or special damages. Contact the Univex service department for any warranty claims.