

Project _____

Item Number _____

Quantity _____

SL120LH / SL120LB



SL120LH / SL120LB
SILVERLINE
Spiral Mixers
with Attached Lifter

Models:

- SL120LH:** 265Lbs (120Kg) Spiral Mixer
- SL120LB:** 265Lbs (120Kg) Spiral Mixer



SILVERLINE Spiral Mixer
with Attached Lifter

Features:

- Stainless steel bowl, spiral dough hook, and shaft
- Separate bowl and agitator motors
- Has two speeds and reverse function
- Control board has separate timers for 1st and 2nd speed
- Mixer is equipped with built in lifter for lifting and dumping of mixed product
- Lifter can tilt machine to the right or left (must specify when ordering)
- Difference between H and B models is the height of the lifter (one for bench top and one for hoppers)
- Safety switches protect operator from injury if bowl lid is open.
- Powerful belt drive provides low vibration, low noise, and economical maintenance for years of reliable service

Dough Capacity:

SL120tilt: 265lb (120kg)

Speeds:

Dough hook:

1st speed: 95rpm

2nd speed: 190rpm

Bowl:

1st speed: 15rpm

Warranty:

- One year, on-site parts and labor

Univex Corporation

Warranty Details

The SILVERLINE Spiral mixers carries a one-year, on-site parts and labor warranty against any flaws in materials and workmanship. This period begins on the date of the purchase and, provided the unit is used in accordance with our instructions, is in full effect for one year from that date. Any work performed under this warranty must be performed between the hours of 8am and 5pm Monday through Friday. Univex will not pay for overtime charges for work performed other than during normal business hours. Damage incurred in transit or from installation error, accident, alteration or misuse is not covered. Univex shall not be liable for any consequential compensatory, incidental, or special damages. Contact the Univex service department for any warranty claims.



Exacting Standards, Just Like yours, since 1948

SILVERLINE Spiral Mixer with Attached Lifter

SL120tilt H/ SL120tilt B

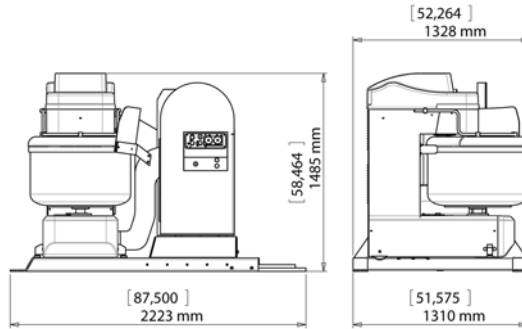
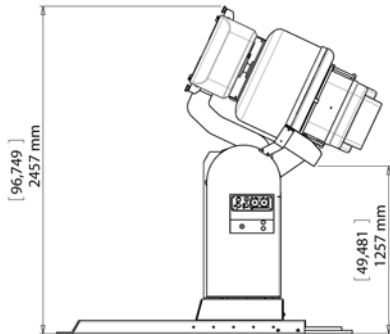

SL120LB

SL120LH

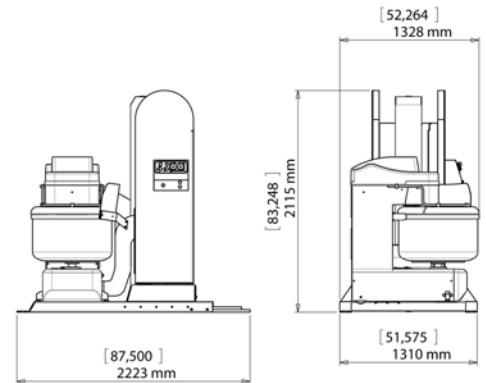
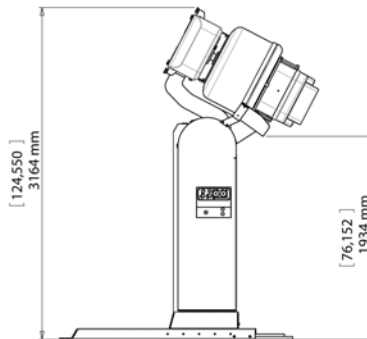

Motor:

Spiral:

SL120LB: 6HP

SL120LH: 6HP

Bowl:

SL120LB: 1HP, 4.48A, .75KW

SL120LH: 1HP, 4.48A, .75KW

Bowl:

SL120LB: 3HP

SL120LH: 3HP

Shipping Information:

SL120LH

SL120LB

Freight Class:

85

85

Net Weight:

3,527lb (1600Kg)

2,866b (1300Kg)

Electrical: 380V/60Hz/3P (Contact factory for alternate voltages)

Controls: Control panel with manual timers. Separate timers for high and low speed. Security key for manual use. Bowl reverse direction switch.

Transmission: Heavy duty low noise, low vibration belt drive

Bowl Guard: Swings open for full access to bowl. Guard must be closed for mixer operation



Univex Corporation
www.Univexcorp.com

3 Old Rockingham Rd
Salem, NH 03079
United States of America

Telephone (800) 258-6358
Intl Tel. (603) 8936191
Fax (800) 356-5614
Intl Fax (603) 8931249