

Project \_\_\_\_\_

Item Number \_\_\_\_\_

Quantity \_\_\_\_\_

SRSD24



## Semi-Automatic Rectangle Divider

SRSD24 (4.23oz to 22.9oz)

### Features:

- Divides dough into even sections
- Produces 24 equal weight and shaped pieces at once
- Can produce 1400 pieces an hour
- Industrial strength machine
- Simple controls

Production estimate is based off a 45 second start-to-finish process with prep time included



Rectangle Divider

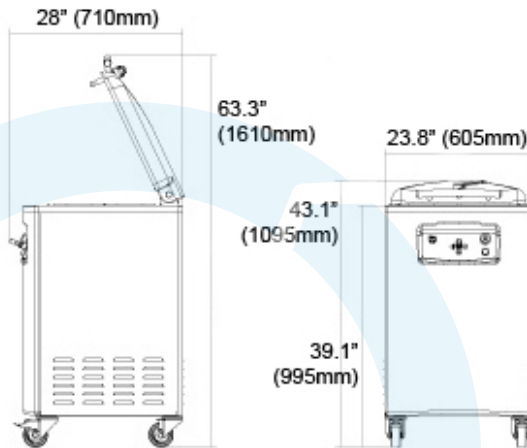

### Shape Detail

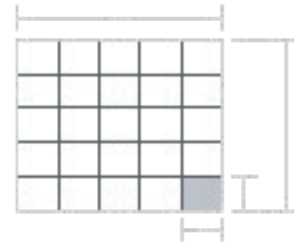

Univex Corporation

### Shipping Information:

| LENGTH        | DEPTH        | HEIGHT        | WEIGHT         |
|---------------|--------------|---------------|----------------|
| 29.5" (750mm) | 57" (1450mm) | 29.5" (750mm) | 507lbs (230kg) |

### Electrical:

220V/60Hz/3Ph

### Warranty:

- One year, on-site parts and labor

#### Warranty Details

The SRSDs carry a one year, on-site parts and labor warranty against any flaws in materials and workmanship. This period begins on the date of the purchase and, provided the unit is used in accordance with our instructions, is in full effect for one year from that date. Any work performed under this warranty must be performed between the hours of 8am and 5pm Monday through Friday. Univex will not pay for overtime charges for work performed other than during normal business hours. Damage incurred in transit or from installation error, accident, alteration or misuse is not covered. Univex shall not be liable for any consequential compensatory, incidental, or special damages. Contact the Univex service department for any warranty claims.