

Project _____

Item Number _____

Quantity _____

Food Processor



Food Processor

Models:

- UFP13

Standard Accessories:

- Aluminium alloy and S/S construction

Food Processor

Features:

- The UFP13 is a versatile vegetable prep machine capable of preparing up to 290 lbs of fresh vegetables, fruit and more per hour
- Heavy duty ventilated motor for continuous operation
- Thanks to its compact design the machine is easy to install inside every kitchen
- The unique feeding system makes it easy to process soft products like mozzarella cheese
- Motor stops when the lever is lifted and the machine does not start if the cover is not in place

Optional Features:

- Large number of discs available for every purpose including specialist slicers, graters and dicers
- Storage basket and tubs

Univex Corporation

Warranty:

- One year, on site parts and labor warranty



Warranty Details

The Food Processor carries a one year, on site parts and labor warranty against any flaws in materials and workmanship. This period begins on the date of the purchase and, provided the unit is used in accordance with our instructions, is in full effect for one year from that date. Any work performed under this warranty must be performed between the hours of 8am and 5pm Monday through Friday. Univex will not pay for overtime charges for work performed other than during normal business hours. Damage incurred in transit or from installation error, accident, alteration or misuse is not covered. Univex shall not be liable for any consequential compensatory, incidental, or special damages. Contact the Univex service department for any warranty claims.



We Raise the Bar. We Set the Standard.

Food Processor

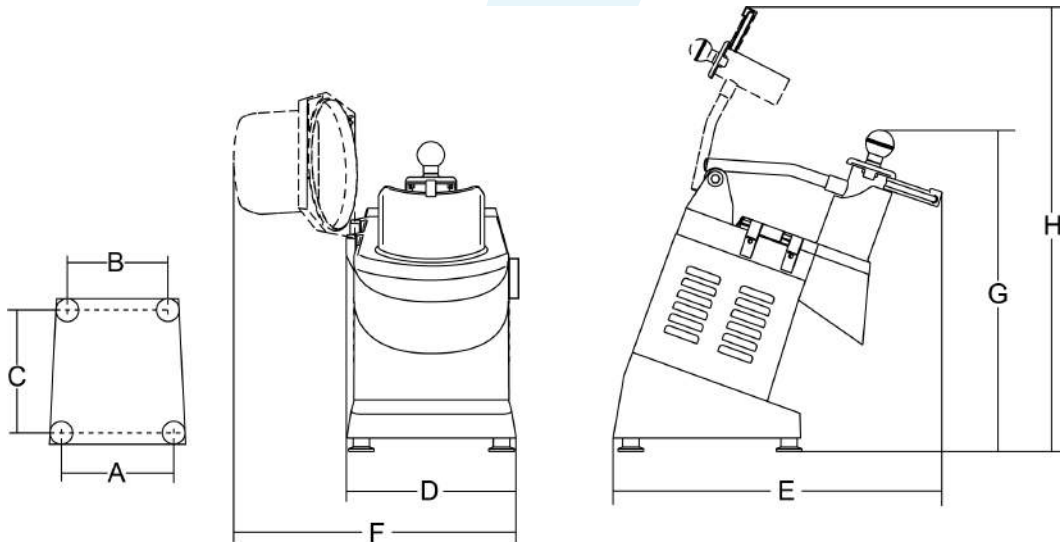

Food Processor Dimensions:

- A 8 7/8"
- B 7 11/16"
- C 10 1/16"
- D 11"
- F 20 1/16"
- G 20 1/16"
- H 30 5/16"

Electrical: 115V, 60Hz, 1Ph
AMPS/ HP: 4.29/ .7
R.P.M: 300

Shipping Information:

Freight Class: 85
Net Weight: 41 lbs
Shipping Weight: 48 lbs

Shipping Box Dimensions:

Height: 19 11/16"
Width: 13 3/4"
Length: 23 3/8"



Univex Corporation
www.Univexcorp.com

3 Old Rockingham Rd
Salem, NH 03079
United States of America

TEL: 800.258.6358
INTL TEL: 603.893.6191
FAX: 800.356.5614
INTL FAX: 603.893.1249