



V5 Food Mixer - 5 Quart Mixer

Project _____

Item Number _____

Quantity _____



The Varimixer Model V5 is an extremely rugged 5-quart mixer, combining an industry leading 0.4 hp direct drive with our proven 5 speed transmission



Intertek
4002624

ETL listed
Conforms to UL Std 763
Certified to CSA Std C22.2 No.195

Standard Features

- Powerful 0.4 hp motor
- Variable Speed Drive with wide agitator speed range from 100 rpm to 400 rpm
- Stainless Steel safety guard
- Aluminum frame with powder coated finish
- Attachment hub
- Permanently lubricated planetary head and attachment hub case
- Safety cut-switch automatically turns the mixer off if mixer is opened.
- Overload protection and no voltage release
- Cord and NEMA 5-15P plug
- ETL and NSF listed
- operated by the 2 rotary knobs, one on each side
- Provisions for bolting to counter or table

Standard Accessories:

- 5 quart bowl - Stainless steel
- Flat beater - Stainless steel
- Spiral dough hook - Stainless steel
- Wire whip - stainless steel wires
- Plastic bowl lid
- Bowl guard ingredient chute
- Splash guard in plastic

Optional Attachments:

- Meat grinder

Warranty:

One year parts and labor limited warranty

Approved By: _____ Date _____

 **Varimixer**
www.varimixer.com

14240 South Lakes Drive
Charlotte, NC 28273
Phone: 800-222-1138
Fax: 704-583-1703
mixer@varimixer.com



V5 Food Mixer - 5 Quart Mixer

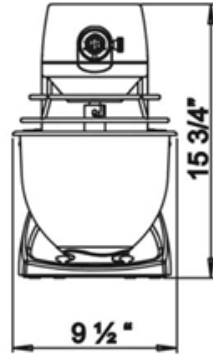
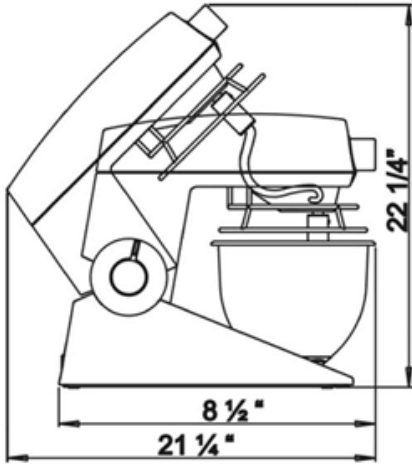

Bowl lid



Splash guard

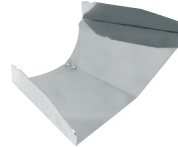

Ingredient chute



Meat grinder 304

Specifications

Model No.	Capacity	Overall size			Net. weight
		Height H	Width W	Length L	
V5A	bowl 5-qt.	15.75" (40 cm)	9.5" (24.13 cm)	21.25" (54 cm)	44 lbs. (20 kg)

Shipping information

Class	CU. FT.	Dimensions			Weight
		Height	Width	Length	
85	25	18" (45.72 cm)	24" (60.96 cm)	18" (45.72 cm)	52 lbs. (23.6 kg)

Cord & Plug	Power cord included with plug NEMA 5-15P		
Electrical Data for Motor	Motor	Volts	Amp
	0.4 HP	115/60/1	3.0
On the nominal motor voltage, + or - 10% tolerance is allowed.			
Mixing Speed			
Agitator Speed	Min	Max	
	100	400	

Capacity Chart

Mashed Potatoes	Whip or Beater	5 lbs.
Whipped Cream	Whip	1 Qts.
Muffins	Beater	5 lbs.
Pie dough	Beater	3 lbs.
Layer Cake	Beater	2 lbs.
Pancake Batter	Whip or Beater	2 Qts.
Cookie Dough	Beater or Hook	3 lbs.
Cookie yeast	Hook	5 lbs.
Donuts, Cake	Beater	5 lbs.
Bread dough (65% AR)	Hook	5 lbs.
Pizza dough (50% AR)	Hook	5 lbs.