



V100 Food Mixer - 100 Quart Mixer

Project	Item Number	Quantity
-----	-----	-----



Variable speed V-belt transmission
 Powerful 4 hp motor for heavy duty purpose



ETL listed
 Conforms to UL Std 763
 Certified to CSA Std C22.2 No.195



Standard Features

- Powerful 4 hp motor for heavy duty purpose
- Variable Speed Drive with wide agitator speed range from 50 rpm to 250 rpm
- Power Bowl Lift
- Top cover, planetary cover and bayonet shaft in stainless steel. Durable powder coated finish used on outside surfaces not constructed of stainless steel
- Rubber feet.
- Stainless Steel bowl screen
- Front mounted controls with 90-minute timer with emergency stop
- No bowl adaptors required for the down-size bowls
- High torque transmission. Grease lubricated, anti friction ball bearings.
- Permanently lubricated planetary head
- Locking pin on tools instead of shaft.
- Safety cut-switch automatically turns the mixer off if bowl screen is opened
- Overload protection and no voltage release
- Bowl truck with double wheel
- 6 feet cord
- ETL and NSF listed

Optional Features

- Mixer in Stainless Steel
- Marine version USPHS
- Prison package
- Mark IV Control System

Accessories:

- 100 quart bowl - stainless steel
- Dough hook - stainless steel and double pin
- Wire whip - stainless steel
- Aluminum flat beater
- 63 quart bowl and accessories
- 42 quart bowl and accessories
- Bowl scraper in 105, 63 and 42 quart sizes
- Stainless steel wing whip
- Stainless steel flat beater
- Reinforced whip
- Stainless steel splash guard
- Bowl guard ingredient chute

Warranty:

One year parts and labor limited warranty

Approved By: _____

Date _____

 **Varimixer**
 www.varimixer.com

14240 South Lakes Drive
 Charlotte, NC 28273
 Phone: 800-222-1138
 Fax: 704-583-1703
 mixer@varimixer.com



V100 Food Mixer - 100 Quart Mixer

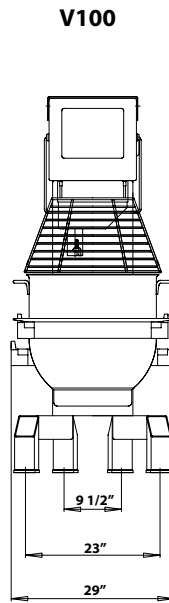
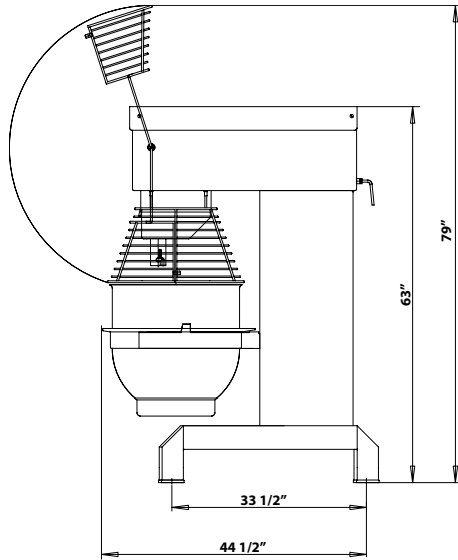

Specifications

Model No.	Capacity	Overall size			Net. weight
		Height H	Width W	Length L	
V100	Large bowl 100 qt. Small bowl 63 qt. Small bowl 42 qt	63" (160.02 cm)	29" (73.66 cm)	44 1/2" (113.03 cm)	870 lbs. (395 kg)

Shipping information

Class	CU. FT.	Dimensions			Weight
		Height	Width	Length	
85	73	78" (198.12 cm)	33" (83.82 cm)	49" (124.4cm)	981 lbs. (444.97 kg)

Cord & Plug	Attached 6 foot flexible 3-wire cord		
Electrical Data for Motor	Motor	Volts	Amp
Standard	4 HP	208/60/3	12.4
Optional	4 HP	480/60/3	6.5
Optional (contact us)	400V, 50Hz		
On the nominal motor voltage, + or - 10% tolerance is allowed.			
Mixing Speed			
Agitator Speed	Min	Max	
	50	250	
Mixer in Stainless Steel Marine version USPHS: Stainless steel execution, stainless steel bowl arms, water cover at air ventilation, slotted free screws, full welded stainless steel knees. Prison package MK IV Control Panel: Programmable electronic panel			

Capacity Chart

Mashed Potatoes	Whip or Beater	76 lbs.
Whipped Cream	Whip	20 Qts.
Muffins	Beater	125 lbs.
Layer Cake	Beater	125 lbs.
Pancake Batter	Whip or Beater	44 Qts
Cookie Dough	Beater or Hook	105 lbs.
Donuts, Yeast	Hook	150 lbs.
Donuts, Cake	Beater	140 lbs.
Bread Dough (65% AR)	Hook	155 lbs.
Pizza Dough (50% AR).....	Hook	135 lbs.

%AR=weight of water
weight of flour

Batch size and/or speed reduction is required if any of the following conditions exist.

1. High Gluten Flour
2. AR % under 40%
3. Water Temperature under 65 Degrees F.

Varimixer

www.varimixer.com

14240 South Lakes Drive
Charlotte, NC 28273
Phone: 800-222-1138
Fax: 704-583-1703
mixer@varimixer.com