



W100PL Food Mixer



Standard Features

- Powerful 4 hp motor
- Variable speeds from 50 to 250 RPM
- Power Bowl Lift.
- Overload protection and no voltage release
- No bowl adaptors required for the down-size bowls
- Locking pin on tools instead of shaft.
- Neoprene feet to minimize walking and rusting
- Permanently lubricated planetary head and attachment hub case
- 15-minute timer with HOLD feature
- Stainless steel 100-qt. bowl, wire whip and dough hook
- Alloy flat beater
- Bowl Truck with Handle

Options & Accessories

- 40-qt. bowl and accessories
- 60-qt. bowl and accessories
- Bowl scraper in 100-qt., 60-qt. and 40-qt. sizes
- Stainless steel wing whip
- Pastry knife
- Mark IV programmable controls
- Ergo (tall column)
- Bowl Screen Ingredient Chute
- Stainless Steel Splash Ring

Specifications

Mixing system

The VARIMIXER W100PL is a planetary mixer with a variable speed drive system. The mixer frame consists of a column with welded-on feet, and a top traverse closed by a stainless steel cover.

The bowl is mounted in bowl arms which are manually raised and locked simultaneously - or lowered and opened, respectively. The column contains the motor and the bowl arm mechanism. The top traverse contains the transmission system consisting of the moveable pulleys, the intermediate belt drive and the planetary head. Start and stop push buttons are mounted on the front plate along with a 15-minute electrical timer with a HOLD feature. Mixing tools are mounted in a bayonet shaft in the planetary head.

Construction

Mixer frame of heavy-gauge, welded, rolled steel plate. Durable powder coated finish used on those surfaces not constructed of stainless steel. Top cover, splash apron and planetary head cap in heavy-gauge stainless steel. Molded PVC feet pads. Bowls in stainless steel. Mixing tools in cast aluminum or stainless steel.

Bayonet shaft in stainless steel. Variable speed V-belt transmission based on precision machined cast iron pulleys. Spring-loaded moveable pulleys in the variable speed drive for automatically adjusting of the tension of the special V-belt. Planetary mixer head of unique design. The planetary head revolves in heavy-duty ball and needle bearings around the main shaft. Precision milled beveled gear on the main shaft engages the bayonet shaft and the fixed internal gear ring through a double set of milled gears obtaining extra high torque capabilities of the mixing tools.

Precision milled cast iron bowl arms lower and raise the bowl and clamp it in a precise position relative to the mixing tool allowing for small tolerances between tool extremities and the bowl.



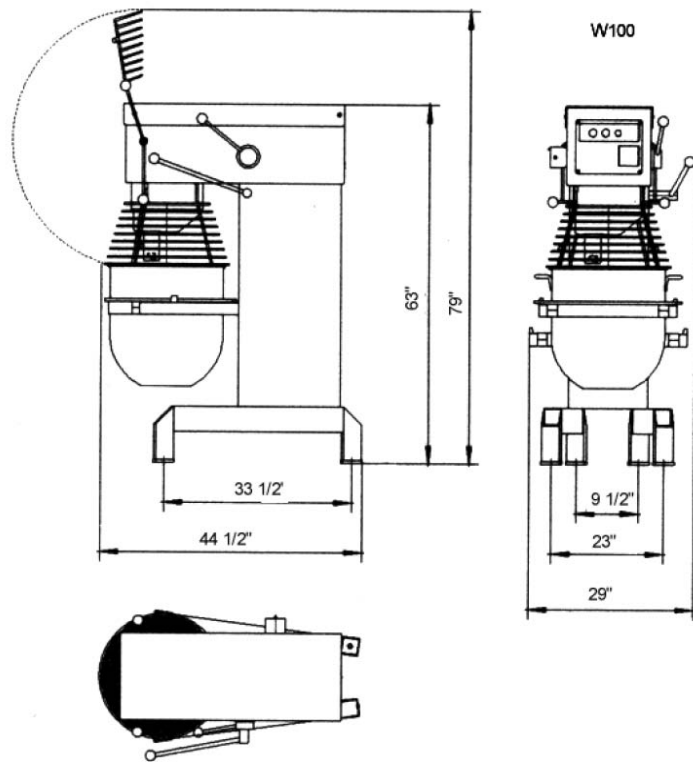

DIMENSIONS

MODEL NO.	CAPACITY	OVERALL SIZE (CM)			NET WEIGHT	SHIPPING INFORMATION					
		HEIGHT	WIDTH	LENGTH		WEIGHT	CLASS	CU. FT.	DIMENSIONS		
W100PL	Large Bowl 100-Qt. Small Bowl 40-Qt. and 60-Qt	63" (160.02 cm)	29" (73.66 cm)	44 1/2" (113.03 cm)	870 lbs. (395 kg)	981 lbs. (444.97 kg)	85	73	H 78" (198.12 cm)	W 33" (83.82 cm)	L 49" (124.4cm)

ELECTRICAL DATA FOR MOTOR

*208-240VAC Supply/60 HZ/3 Phase
 Wires (including Ground).....4
 Motor PowerHP4
 Amperes, full loadA13
 No power cord included

MIXING SPEED

Agitator SpeedMin.50
 Agitator SpeedMax250

%AR= weight of water
 weight of flour

Batch size and/or speed reduction is required if any of the following conditions exist.

1. High Gluten Flour
2. AR % under 40%
3. Water Temperature under 65 Degrees F

*On the nominal motor voltage, + or - 10% tolerance is allowed.

** Also available in 480/60/3, 380/50/3, 220/50/3, 220/50/1, - not submitted for UL listing.

CAPACITY CHART

Mashed Potatoes	Whip or Beater	76 lbs.
Whipped Cream	Whip	20 Qts.
Muffins	Beater	125 lbs.
Layer Cake	Beater	125 lbs.
Pie Dough	Pastry Knife	95 lbs.
Pancake Batter	Batter Whip or Beater	44 Qts
Cookie Dough	Dough Beater or Hook	105 lbs.
Donuts, Yeast	Hook	150 lbs.
Donuts, Cake	Beater	140 lbs.
Bread Dough (65% AR)	Hook	155 lbs.
Pizza Dough (50% AR)	Hook	135 lbs.



Standard tools: Beater, whip and hook.