



## W20SF Food Mixer



### Standard Features

- Stainless steel body, legs, top cover planetary cover, beater shaft, bowl, beater, whip wires and bowl screen.
- Powerful 1 hp motor with cord and NEMA 5-15P plug
- Overload protection and no voltage release
- Bowl Screen
- Neoprene feet to minimize walking, rusting or counter damage
- Provisions for bolting to counter or table
- Permanently lubricated planetary head and attachment hub case

### Options & Accessories

- 12-qt. bowl and accessories
- Bowl scraper in 20-qt. and 12-qt. sizes
- Stainless steel wing whip
- Pastry knife
- Dough Hook
- Bowl Screen Ingredient Chute
- 25-qt. stainless steel bowl
- Stainless table with legs
- Stainless table with castors
- Stainless steel base.  
(Tables and Base shown below)

### Specifications

#### General Description

The Varimixer Model W20SF is our most rugged 20-quart mixer, combining an industry-leading 1 hp drive with our proven variable speed transmission. This combination provides plenty of torque at the beater shaft for maximum batch sizes. The W20SF features very efficient agitators to quickly produce quality food products.

The W20SF can be equipped with a stainless steel automatic bowl scraper. The bowl scraper eliminates intermediate stopping during recipe preparation, saving time and improving sanitation.

The W20SF features a wide agitator speed range from 100 rpm to 400 rpm. The W20SF has the versatility and the performance to handle all your mixing needs from cake mix to the lightest whipped cream.

The W20SF frame is of welded stainless steel construction for strength and rigidity. All ball bearings and needle bearings are sealed to protect from foodstuff and moisture damage. Durable powder coating finish is used on those surfaces not constructed of stainless steel.

Stainless steel is extensively used in the construction of the W20SF for quick cleanup and long life. The top cover, planetary cover, all agitator shafts, bowl, beater, whip wires, control handles and bowl clamps are constructed of stainless steel.



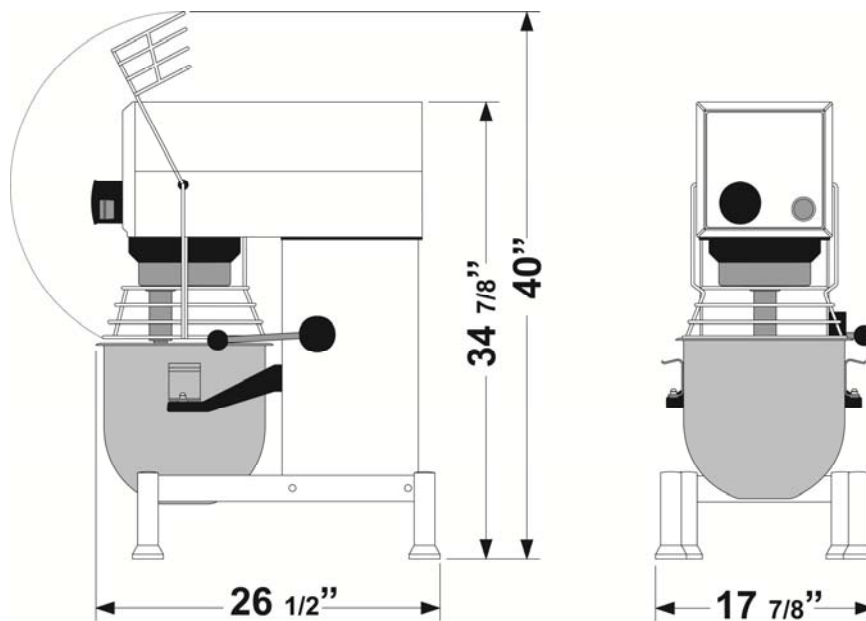

**DIMENSIONS**

MODEL NO.	CAPACITY	OVERALL SIZE (CM)			NET WEIGHT	SHIPPING INFORMATION					
		HEIGHT	WIDTH	LENGTH		WEIGHT	CLASS	CU. FT.	DIMENSIONS		
W20SF	Large Bowl. 20-Qt. Small Bowl 12-Qt.	34.875" (88.6 cm)	17.7" (450 cm)	26.5" (67.3 cm)	216 lbs. (98kg)	293 lbs. (133 kg)	85	25	<b>H</b> 47" (119.4 cm)	<b>W</b> 29" (73.7 cm)	<b>L</b> 32" (81.3 cm)

**ELECTRICAL DATA FOR MOTOR**

\*115VAC Supply/60 HZ/1 Phase  
 Feed Wires incl. Ground.....3  
 Motor Power .....HP .....1  
 Amperes, full load .....A .....12  
 Power cord included with plug NEMA 5-15P

**MIXING SPEED**

Agitator Speed .....Min. ....100  
 Agitator Speed .....Max .....400

**%AR= weight of water**  
 weight of flour

Batch size and/or speed reduction is required if any of the following conditions exist.

1. High Gluten Flour
2. AR % under 40%
3. Water Temperature under 65 Degrees F

\*On the nominal motor voltage, + or - 10% tolerance is allowed.

\*\*Also available in 220/60/1, 220/50/1, 110/50/1 and 440/60/3. Not submitted for UL listing.

**CAPACITY CHART**

Mashed Potatoes	Whip or Beater	17 lbs.
Whipped Cream	Whip	4 Qts.
Muffins	Beater	24 lbs.
Layer Cake	Beater	23 lbs.
Pie Dough	Pastry Knife	21 lbs.
Pancake	Batter Whip or Beater	9 Qts.
Cookie	Dough Beater or Hook	14 lbs.
Donuts, Yeast	Hook	20 lbs.
Donuts, Cake	Beater	23 lbs.
Bread Dough (65% AR)	Hook	25 lbs.
Pizza Dough (50% AR)***	Hook	12 lbs.



Standard tools: Stainless Steel flat beater and wire whip.