



110 Woodcrest Road, Cherry Hill, NJ 08003-3648
 856.428.4200 • 800.523.5008 • Fax: 856.428.7299
 www.victoryrefrigeration.com • email: sales@victoryrefrigeration.com



PROJECT: _____
 LOCATION: _____
 ITEM #: _____
 QUANTITY: _____

V-SERIES™ HORIZONTAL LINE

UNDERCOUNTER & WORKTOP REFRIGERATORS VUR 36" SST/SBS

STANDARD FEATURES

- Stainless Steel Doors, Front, Tops, Sides and Interior Floor with Aluminum Interior Walls and ABS Door Liner. Galvanized Back
- Stainless Steel Top
- Stainless Steel Backsplash (SBS Models Only)
- Flush, Ergonomic Integrated Handles
- Front-Breathing Refrigeration System
- Enhanced Interior Cabinet Air Flow
- Meets Tough NSF Standard 7, 41° F
- Full Electronic Control with Front Mounted LED Display
- Environmentally Friendly R-134a Refrigerant
- CFC and HCFC Free Polyurethane Insulation
- Anti-Corrosion Coated Evaporator Coil
- Non-Electric Evaporation of Condensate Water
- Cam-Lift Hinges with a 120° Hold Open Feature
- Snap-in Place Magnetic Door Gasket(s)
- Energy Saving Thermal Breaker Caps
- Anti-Condensate Door Perimeter Heaters
- 6" Overall Height Casters with Brakes
- Two Epoxy Coated Shelves per Section
- Cord and Plug Attached

OPTIONS AND ACCESSORIES

- Drawer Module(s)
- ADA Compliant 3" Diameter Casters
- 6" Overall Height Adjustable SS Legs
- Single and Double Overshelves
- Stainless Steel Back
- Cylinder Locks for Doors
- Optional Voltages: 220/50/1, 220/60/1

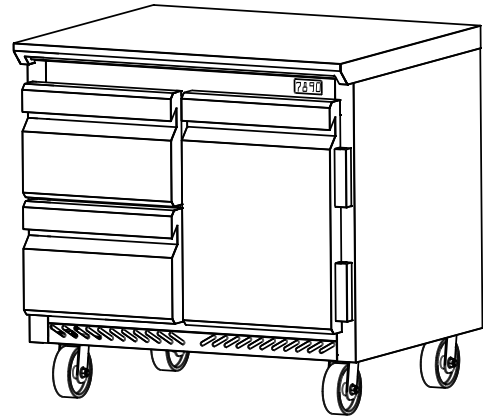

VUR-36-SST-2

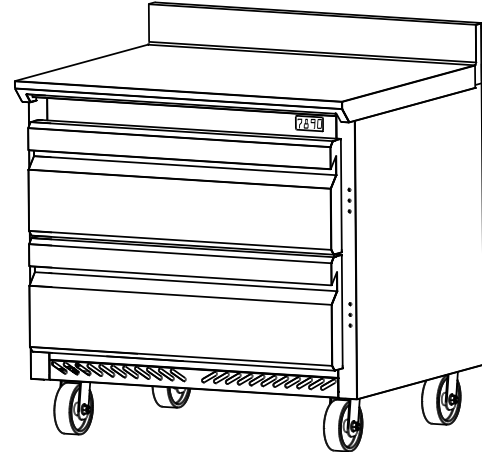

VUR-36-SBS-2W

MODELS

SST DOOR	SST DRAWER	SBS DOOR	SBS DRAWER
VUR-36-SST	VUR-36-SST-2	VUR-36-SBS	VUR-36-SBS-2
	VUR-36-SST-2W		VUR-36-SBS-2W
	VUR-36-SST-4		VUR-36-SBS-4

3 Year Parts and Labor Warranty
 5 Year Compressor Warranty



Note: Not all markings apply to all model variations.

Victory Refrigeration specification sheets are available online at www.victoryrefrigeration.com

APPROVALS:

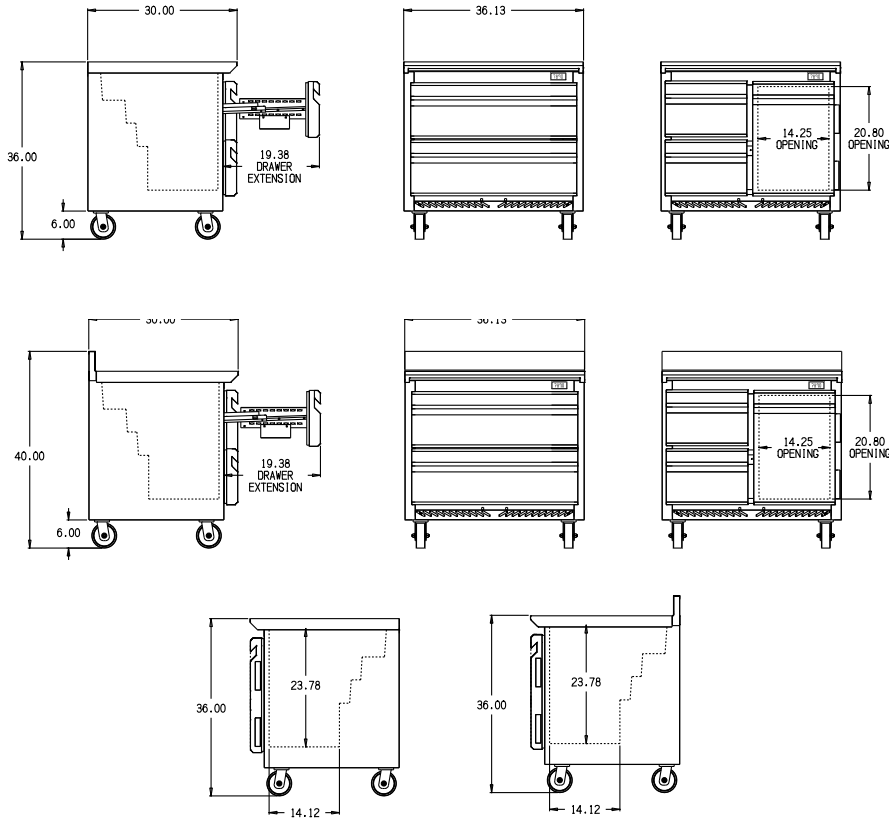

Dimensional tolerances +/- 1/4". Metric dimensions (MM)

We reserve the right to change specifications and product design without notice. Such revisions do not entitle the buyer to corresponding changes, improvements, additions or replacements for previously purchased equipment.

CHARACTERISTICS	VUR-36-SST/SBS	VUR-36-SST/SBS-2	VUR-36-SST/SBS-2W	VUR-36-SST/SBS-4
DIMENSIONAL DATA				
Width, Overall (in.)	36.13	36.13	36.13	36.13
Depth, Overall (in.)	30	30	30	30
Height, Overall (in.)	36/40	36/40	36/40	36/40
Height, Work Area (in.)	36	36	36	36
Drawer, Extension Overall (in.)	N/A	19.38	19.38	19.38
Depth w/Door Open 90° (in.)	45.38	N/A	N/A	45.38
Capacity Net (cubic feet)	8.2	8.2	8.2	8.2
No. of Shelves	4	N/A	N/A	N/A
No. of Doors	2	N/A	N/A	N/A
No. of Drawers	N/A	2	2	4
ELECTRICAL DATA				
Cabinet Voltage	115/60/1	115/60/1	115/60/1	115/60/1
NEMA Plug	5-15p	5-15p	5-15p	5-15p
Total Amperes	5.4	5.4	5.4	5.4
REFRIGERATION DATA				
Condensing Unit Size (hp)	1/5	1/5	1/5	1/5
Refrigerant	R-134a	R-134a	R-134a	R-134a
CRATED DIMENSIONS & WTS.				
Height, Overall (in.)	49.00	49.00	49.00	49.00
Width, Overall (in.)	53.50	53.50	53.50	53.50
Depth, Overall (in.)	39.50	39.50	39.50	39.50
Cubic Feet	59.92	59.92	59.92	59.92
Crated Weight (lbs)	230/235	255/260	270/275	280/285

DRAWER CAPACITY

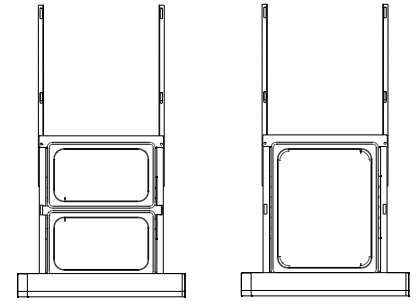

PANS: (2): 1/4

PANS: (1)-1/2

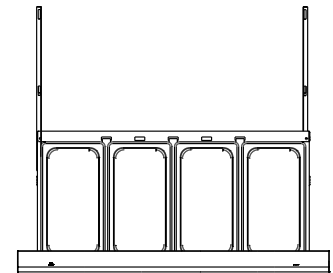

PANS: (4): 1/3

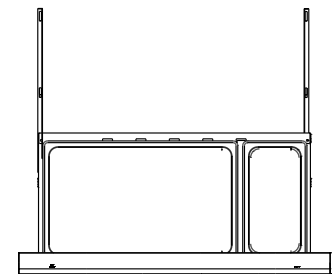

PANS: (1): FULL & (1): 1/3

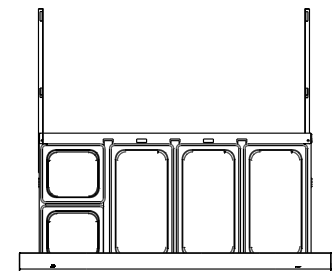

PANS: (2): 1/6 & (3): 1/3