



Project:

Item Number:

Quantity:

Short Side Drop-in: NSF7 Refrigerated Cold Pans

The Vollrath Company, L.L.C.

SHORT SIDE DROP-IN: NSF7 REFRIGERATED COLD PANS

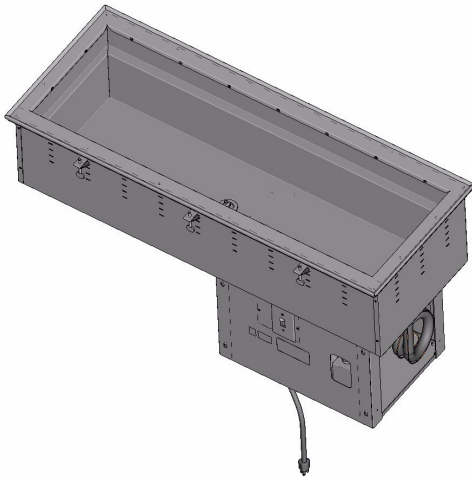

Short Side Drop-In: NSF7 Refrigerated Cold Pans

DESCRIPTION

The short side drop-in NSF7 refrigerated cold pans are designed for top-mount installation.

A full-perimeter drip edge contains spills and condensation within the stainless steel countertop area of the drop-in.

High-density polyurethane foam insulation surrounds the exterior of the well to provide the most efficient performance with energy savings.

A 3" (7.62 cm) recess lowers the food pan below the work surface to minimize the impact of ambient air. The 6 5/8" (16.8 cm) deep display well is designed to accommodate standard 12" x 20" (30.4 cm x 50.8 cm) pans up to 6" (15.24 cm) deep.

Refrigeration coils surround the exterior side walls of well for maximum cooling. Refrigerant is R134A to meet federal standards.

1" (2.5 cm) integrated drain is standard. Optional perforated false bottom.

Modular drop-in orders cannot be canceled or returned

Agency Certifications



Due to continued product improvement, please consult www.vollrathco.com for current product specifications.

- MODELS**
- 36653 Two Pan
 - 36656 Three Pan
 - 36659 Four Pan

FEATURES

- Top is 18-gauge stainless steel, with 3/8" (9.52 mm) overhang on all sides and die stamped with full-perimeter drip edge. Molded breaker gasket fitted under drip edge.
- Flat work surface around opening.
- Seamless well is 18-gauge stainless steel, 6 5/8" (16.8 cm) deep.
- 1" (2.5 cm) integral drain is standard.
- Refrigeration coils surround exterior side walls of well.
- Inner well assembly insulated with foamed-in-place polyurethane foam insulation.
- Condensing unit suspended below well.
- Temperature control on compressor.
- For complete air circulation, two 8" x 10" (20.3 cm x 25.4 cm) openings in the cabinet are required.
- Exterior housing is 18-gauge galvanized steel.
- Optional perforated false bottom is nominal 1" (2.5 cm) high and constructed of 18-gauge Type 304 stainless steel. False bottom will reduce pan depth by same dimension. False bottom options:

Drop-In Model	False Bottom Model
36653	70100 – Quantity 2
36656	70100 – Quantity 3
36659	70100 – Quantity 4

- Unit comes with a cord and plug and does not require hard wiring.
- On/Off switch is mounted on the side of the compressor housing.
- Positioning clips are provided to center the drop-in within the cutout.
- One year parts and labor warranty. Additional four years on compressor.
- Cold drop-ins are best used for holding periods up to 4 hours. For best performance, stainless steel containers are recommended.

Approvals

Date:



Setting the Standard™

www.vollrathco.com

The Vollrath Company, L.L.C.
 1236 North 18th Street
 Sheboygan, WI 53081-3201
 U.S.A.
 Main Tel: 800.628-0830
 Service Tel: 800.628.0832
 FAX: 800.752.5620

Vollrath of Canada, Co.
 Tel: 800.695.8560
 FAX: 800.752.5620

SHORT SIDE DROP-IN: NSF7 REFRIGERATED COLD PANS

MODELS 36653 Two Pan
 36656 Three Pan
 36659 Four Pan

DIMENSIONS

- Opening cutout must have a $\frac{7}{8}$ " (2.22 cm) corner radius.
- Dimensions shown in inches (cm).

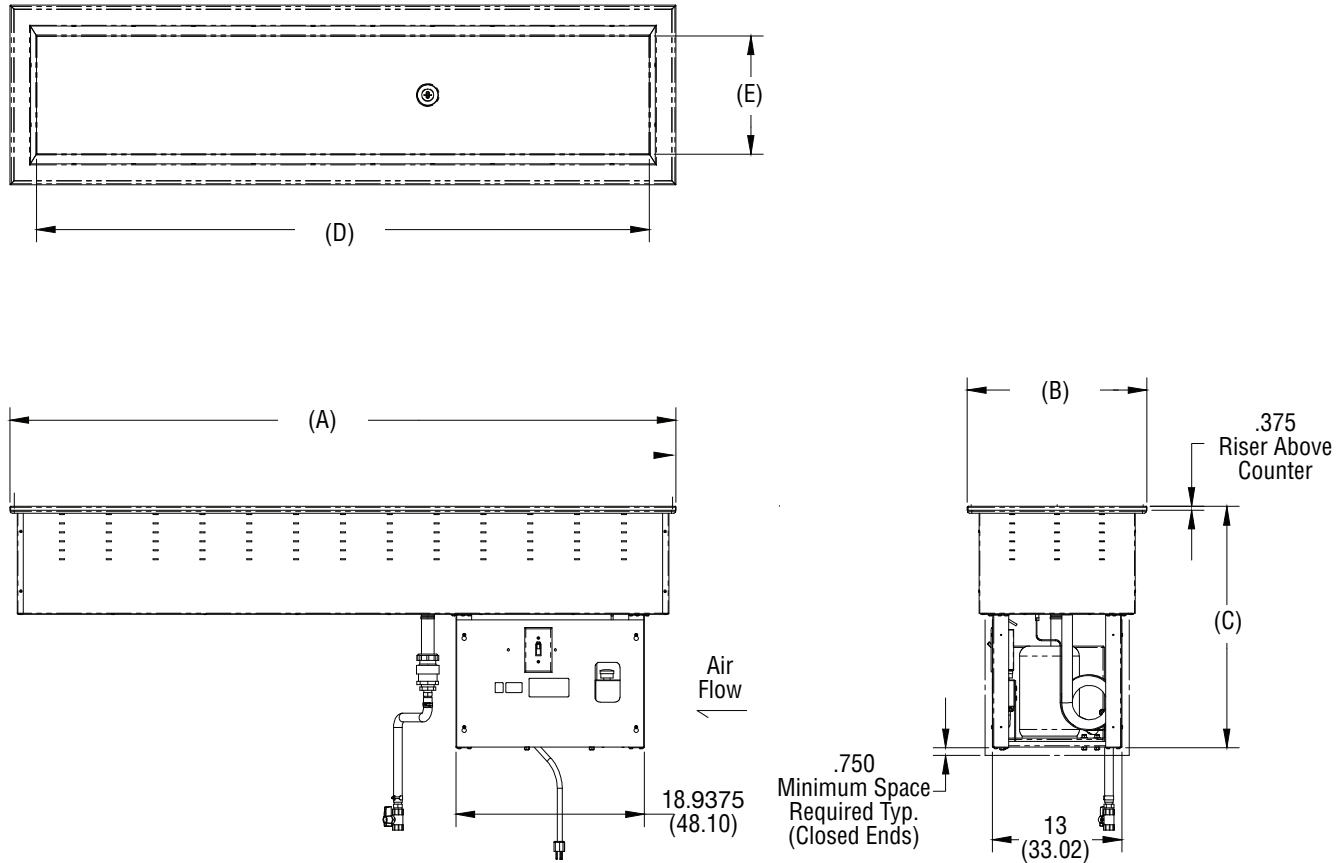

Item	(A) Length	(B) Width	(C) Height	Display Area		Cutout		Comp	Voltage	Amps	Plug	Receptacle
				(D)	(E)	Length	Width					
36653	45.437 (115.411)	18.062 (45.878)	24.125 (61.277)	40.75 (103.50)	11.875 (30.162)	44.687 (113.506)	17.312 (43.973)	1/4 HP	120	4.9	5-15P	5-15R
36656	66.812 (169.703)	18.062 (45.878)	24.125 (61.277)	61.50 (156.21)	11.875 (30.162)	66.125 (167.957)	17.312 (43.973)	1/4 HP	120	4.9	5-15P	5-15R
36659	88.25 (224.155)	18.062 (45.878)	24.125 (61.277)	82.25 (208.915)	11.875 (30.162)	87.50 (222.25)	17.312 (43.973)	1/4 HP	120	4.9	5-15P	5-15R



www.vollrathco.com

The Vollrath Company, L.L.C.
 1236 North 18th Street
 Sheboygan, WI 53081-3201
 U.S.A.
 Main Tel: 800.628-0830
 Service Tel: 800.628.0832
 FAX: 800.752.5620

Vollrath of Canada, Co.
 Tel: 800.695.8560
 FAX: 800.752.5620