



Project:

Item Number:

Quantity:

FOOD PROCESSOR



Food Processor

MODELS

40826 Commercial Food Processor

FEATURES

- Chops, mixes, and blends
- Suitable for continuous use applications
- Anodized aluminum body and stainless steel bowl for attractive look and easy cleaning
- Removable stainless steel "S" blade and bowl for easy cleaning
- Safety cutoff switch stops blade when lid is removed
- Non-skid rubber feet

DESCRIPTION

A right-on-the-money Commercial Food Processor that gives you the functionality you need, in an efficient, heavy-duty package. Great for preparing pâtés, mayonnaise, salsa, and guacamole, and for chopping nuts and vegetables. Ideal unit for pizza toppings and Mexican sauces, or to puree patients' food in hospitals and assisted living facilities.

Agency Listings



Due to continued product improvement, please consult www.vollrathco.com for current product specifications.

Approvals

--

Date:



Setting the Standard™

www.vollrathco.com

The Vollrath Company, L.L.C.
1236 North 18th Street
Sheboygan, WI 53081-3201 U.S.A.
Customer Service: 800.628.0830
Canada Customer Service: 800.695.8560
Main Fax: 800.752.5620 or 920.459.6573

Technical Services: 800.628.0832
Technical Services Fax: 920.459.6573

FOOD PROCESSOR

MODELS 40826 Commercial Food Processor

DIMENSIONS

Dimensions shown in inches (cm).

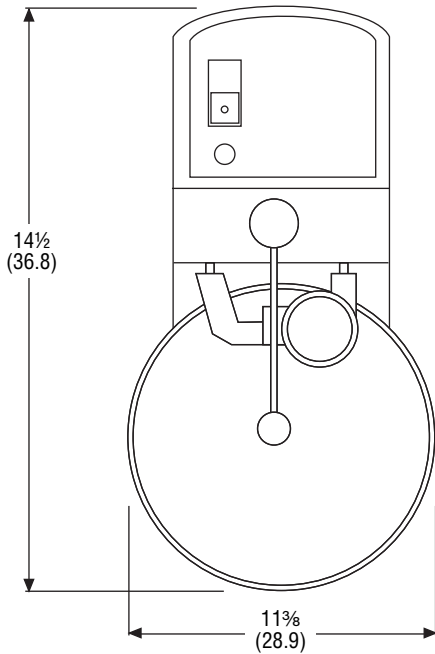

Top View

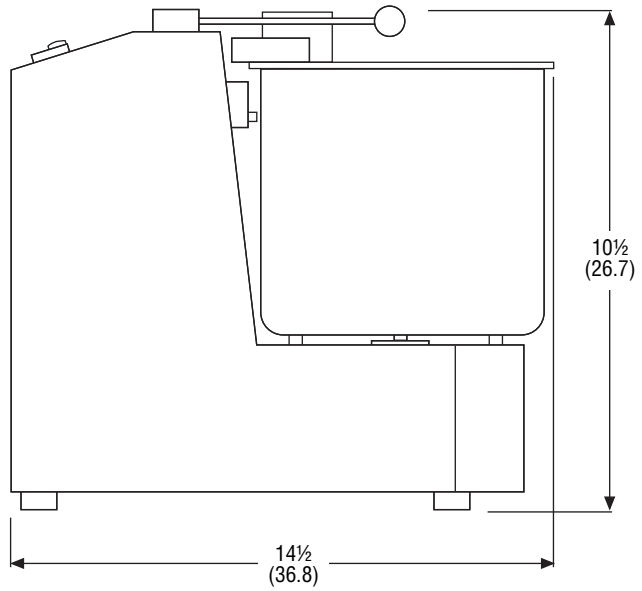

Side View

SPECIFICATIONS

Item	Capacity	Voltage	HP	Amps	Plug
40826	3 Qt	115	1/3	2.6	5-15P

Receptacles

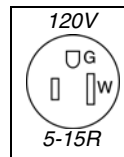

www.vollrathco.com

The Vollrath Company, L.L.C.
 1236 North 18th Street
 Sheboygan, WI 53081-3201 U.S.A.
 Customer Service: 800.628.0830
 Canada Customer Service: 800.695.8560
 Main Fax: 800.752.5620 or 920.459.6573

Technical Services: 800.628.0832
 Technical Services Fax: 920.459.6573