



Project:

Item Number:

Quantity:

PROFESSIONAL SERIES DROP-IN INDUCTION RANGES



Professional Series Drop-in Induction Ranges

DESCRIPTION

These high-efficiency, heavy-duty professional drop-in induction ranges are designed for use in commercial kitchens and front-of-the-house cooking. They provide sensitive low-end control for cooking sauces, milks and chocolates as well as fast, high temperature cooking.

The case is made from 18-gauge 304 stainless steel with a vitro ceramic top. The ceramic top is easily cleaned with a mild cleaner.

The induction range is equipped with a variety of safety features including:

- Over-heat protection
- Small-article detection
- Pan auto-detection function
- Empty-pan shut-off

Agency Listings



This device complies with Part 18 FCC Rules.

Due to continued product improvement, please consult www.vollrathco.com for current product specifications.

MODELS

69521 Single Hob Drop-in (US/Canada)

69524 Dual Hob Drop-in – Front to Back (US/Canada)

FEATURES

- G4 engine for long life
- 100 settings for precise cooking control – set to power level or temperature setting
- 90% efficiency rating
- Continuous duty induction circuitry for non-stop cooking
- Firewall protected circuitry with oversized fans and 18 gauge heavy-duty 18-8 stainless steel casing
- 1-180 minute timer – unit shuts off at end of cycle
- Digital display is easy to clean – no knobs to collect food and it helps prevent accidental temperature changes
- "HOT" warning display for safety
- Three-foot remote control cord on drop-in models
- FCC Part 18 Approved
- Units come with 6' (183 cm) cord and plug and do not require hard wiring
- Rubber feet to prevent slipping of appliance
- Full two-year parts and labor warranty

IMPORTANT

- This appliance is intended for use with induction-ready cookware.
- All models require unrestricted intake and exhaust air ventilation for proper operation of the controls. The maximum intake temperature must not exceed 110°F (43°C). Temperatures are measured in ambient air while all appliances in the kitchen are in operation.
- Drop-in models require a minimum clearance of 3 inches (7.6 cm) at the rear and 1 inch (2.5 cm) at the bottom.

WARRANTY: All models shown come with Vollrath's standard warranty against defects in materials and workmanship. For full warranty details, please refer to the Vollrath Equipment and Smallwares Catalog.

Approvals	Date



Setting the Standard™

www.vollrathco.com

The Vollrath Company, L.L.C.
1236 North 18th Street
Sheboygan, WI 53081-3201 U.S.A.
Customer Service: 800.628.0830
Canada Customer Service: 800.695.8560
Main Fax: 800.752.5620 or 920.459.6573

Technical Services: 800.628.0832
Technical Services Fax: 920.459.5462

PROFESSIONAL SERIES DROP-IN INDUCTION RANGES

MODELS 69521 Single Hob Drop-in (US/Canada)
 69524 Dual Hob Drop-in – Front to Back (US/Canada)

DIMENSIONS

Dimensions shown in inches (cm).

69521

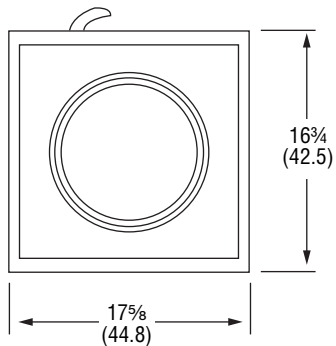

Top View

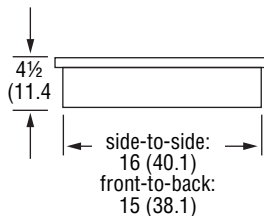

Side View

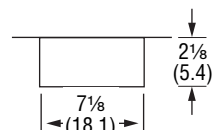
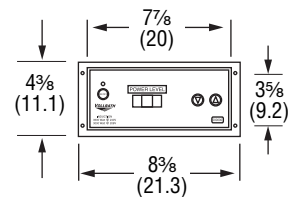

Control

69524

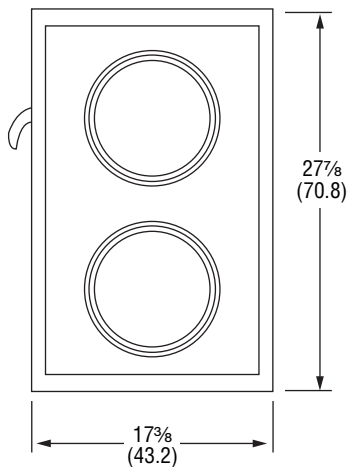

Top View

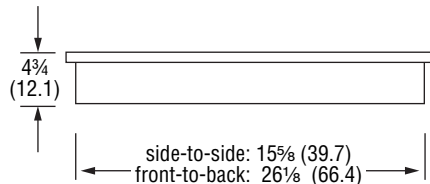

Side View

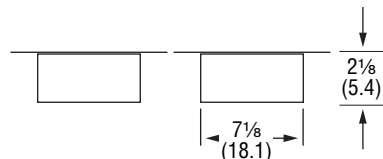
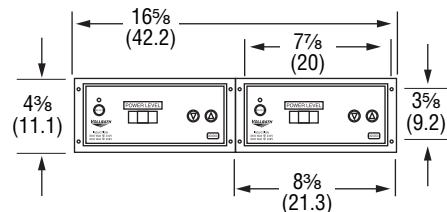

Control

SPECIFICATIONS

Model	Max Pan Size	Drop-in Cutout	Control Cutout	Voltage	KW	Amps	Plug	Shipping Container	Shipping Weight
69521	14 (35.6)	16 1/8 x 15 1/8 (40.9 x 38.4)	7 1/4 x 3 7/8 (18.4 x 9.8)	208/240 AC	2.5 - 2.9	12.1	6-20P	19 1/2 x 24 1/4 x 10 (49.5 x 61.6 x 25.4)	25.4 (11.5)
69524	12 (30.5)	26 3/8 x 15 7/8 (67 x 40.3)	7 1/4 x 3 7/8 (x 2) (18.4 x 9.8) (x 2) Two separate control boxes. Minimum spacing for control panels is 16 5/8 (42.2)	208/240 AC	2.5 - 2.9 Per Hob	24.2	6-30P	33 x 23 3/8 x 10 (83.8 x 59.4 x 25.4)	43.6 (19.8)

Receptacles

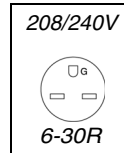
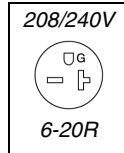

www.vollrathco.com

The Vollrath Company, L.L.C.
 1236 North 18th Street
 Sheboygan, WI 53081-3201 U.S.A.
 Customer Service: 800.628.0830
 Canada Customer Service: 800.695.8560
 Main Fax: 800.752.5620 or 920.459.6573

Technical Services: 800.628.0832
 Technical Services Fax: 920.459.5462